



REDISCOVER THE COMPACT BUS CLASS



4 MODELS TO FALL IN LOVE WITH

VANs to give you more? When it comes to choosing, the only choice is VANLINE. Citroën or Mercedes, permanently mounted furniture plus kitchen (swivel-mounted) or Campbox – the PÖSSL GROUP's Vanline has everything the Camper enthusiast's heart could desire.

VANSTER!

CAMPSTER!

Vanst★F

Campst★F





THE VANLINE

A STORY OF CAMPERVAN SUCCESS

4 strong characters for an
unforgettable travel experience

It all began back in 2016, when the camper world first glimpsed the CAMPSTER with its Citroën Spacetourer base.

This heralded the start of Pössl's successful era as a camping van maker. With the VANSTER – also available with a Peugeot Traveller base – came a light-weight version featuring the Campbox as an alternative to fully furnished models with a permanently installed kitchen.

In 2021, the Pössl Group introduced two new brightly shining stars to the camping van scene - the CampStar and the VanStar models.



Paths are made by walking.
And we are blazing the trail
to e-mobility camping for
our customers.

Robert Hein,
Camping Van Product Development

With the Mercedes V Class
and Vito Tourer Pro based versions,
the Pössl Group continues the tried
and trusted fully-fitted camping
van concept: with a large panorama
pop-top roof, permanently installed
furniture and swivel-mounted Easy
Move Kitchen on the one hand,
and the Campbox on the other, the
camping experience now knows no
limits.



THE VANLINE SUCCESS STORY



2016 // THE VANLINE STORY BEGINS

With the CAMPSTER – featuring a Citroën Spacetourer base, fully-fitted furniture and pop-top roof - PÖSSL makes a triumphant entry into the compact bus class.



2017 // THE PÖSSL GROUP GROWS

A new production company, H-Line Produktion GmbH, is established in Vielbrunn/Odenwald. As a result, a modern production centre is created on some 50,000 m² of space - the Vanster is built here starting in 2019, followed later by the Vanstar and Campstar.



2020 // THE VANLINE BEGINS

The season starts with the launch of the VANSTER – in contrast to the CAMPSTER, rather than having permanent furnishings, it is the perfect everyday run-about with up to eight seats, a pop-top roof and optional Campbox with cooking and sleeping facilities. The same year sees the première of both full conversion models with Mercedes Vito and V Class base: VANSTAR and CAMPSTAR join the team with the other two vans. The VANLINE range is created – the PÖSSL GROUP's compact bus class.

2021 // THE SECOND PRODUCTION CENTRE

The Dachwig plant close to Erfurt, goes into operation. Here the VANSTER are produced with the latest state-of-the-art laser-cut cabs.

2024// THE PÖSSL VANLINE IS WELCOMING SOME NEW FACES

With the arrival of the latest upgrade to the Stellantis range of urban vehicles, the Pössl Group is also giving its youngsters some new looks. The Campster / Vanster, but also the Campstar / Vanstar are gaining a whole new lustre, both inside and out.





OUR MODELS PRESENTING A STYLISH APPEARANCE EVERYWHERE



VANSTER!

Page 10-17

THE VAN WITH A PLAN

Because whatever you're doing right now – with its versatility, it's the perfect companion for day-to-day living and recreational time.



CAMPSTER!

Page 10-11 / 18-23

THE ONE FOR EVERYTHING AND EVERYBODY

The CAMPSTER is a vehicle for living. It opens up boundless possibilities to do everything a modern automobile can do.



Vanstar

Page 24-33

THE ALL-ROUND VAN WITH A STAR

The VANSTAR is aptly named: Take the kids to football training, or on a four-week travel adventure – everything's possible, nothing's a must.



Campstar

Page 24-25 / 34-41

THE STAR THAT CAN DO EVERYTHING

The CAMPSTAR will win you over with its multi-functionality and individually selectable equipment options. It turns every trip and every journey into a unique experience.

TWO OF A KIND

In their own special way, the VANSTER and CAMPSTER give you what you need day-to-day, on weekend trips or for going away on holiday. What are you waiting for?

VANSTER!

CAMPSTER!



■ ELEGANT EXTERIOR

With its flowing lines, body-colour bumpers and 17" light alloy wheels with summer tyres (as standard), your VANSTER and CAMPSTER epitomises safety, agility and elegance.

■ TWO SLIDING DOORS

Your bus is open to everything and from every side. The two large sliding doors are not merely practical, they also turn every stop into an open-air event.

■ CLEAR TO ENTER EVERY MULTI-STOREY CAR-PARK

At just 1.99 m high (height may differ if vehicle is reloaded for greater weight), your bus can enter any conventional multi-storey car-park without risking frontal impact to the roof. An advantage that not every vehicle in this category can offer.

■ SUPERB HANDLING

The outstanding suspension ensures optimum driving comfort and excellent steering precision, whatever the road.

■ SAFE ON THE ROAD

Your VANSTER and CAMPSTER already come with numerous safety systems as standard:

- Vision pack (rain sensor, light sensor, automatic dimming rear-view mirror)
- LED headlamps
- ABS & ESC
- driver fatigue detector
- speed assist
- digital cockpit
- e-call
- and lots more ...

■ SEPARATELY OPENING REAR-WINDOW

The separately opening rear-window means that individual items can be quickly stowed in the luggage compartment. Exceptionally practical whenever there's not enough space to open the tailgate.

■ ALMOST LIKE AT HOME

Onboard, the elevated onboard seat position and ultra-variable, comfy interior with up to 4 berths* below and in the roof above create a feeling of being inside your own four walls.

eVANSTER - YOUR ADVENTURE, ELECTRICALLY CHARGED

INTELLIGENT POWER
CONSUMPTION DISPLAY



75 KWH BATTERY CAPACITY



RECUPERATION FOR
CHARGING WHILE DRIVING



ELECTRIC PARKING BRAKE
(E-VANSTER)



BLIND-SPOT DETECTION SYSTEM*



AUTOMATIC HIGH BEAM ASSISTANT*



TRAFFIC SIGN RECOGNITION*



ATTENTION ASSIST*



LANE DEPARTURE WARNING*



- **VANSTER FACTORY-FITTED WITH:**
 - RCC audio system with DAB with Bluetooth hands-free unit, USB
 - Auxiliary air conditioning in rear
 - Swivel driver and passenger seats
 - Flip-up induction hob in the tail garage and a 220 V CEE external power socket

- **ADDITIONAL STANDARD EQUIPMENT**
 - Mode 2 charging cable
 - Parking assist with camera
 - Tinted windows
 - 75 kWh battery
 - Citroën Connect Box

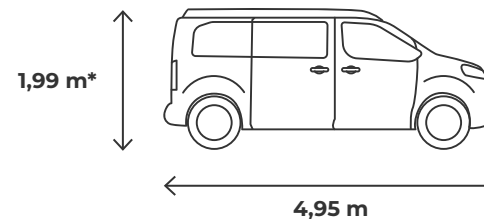

Peugeot
Citroën

VANSTER!

THE VAN WITH A PLAN

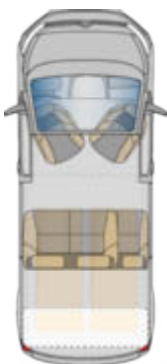

It's like the VANSTER is tailor-made for every situation in your life. Whether it's doing the weekly shop, transporting bulky items, heading off to the countryside with bikes onboard, or – thanks

for the practical pop-top roof with sleeping berth – taking that spontaneous camping trip over a long weekend. The VANSTER has something for everyone. Simply more van for less money.

HIGHLIGHTS

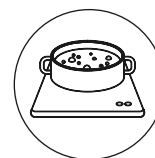

INDUCTION HOB

Flip-up induction hob in the tail garage and a 230 V CEE external socket as standard equipment.



POP-TOP ROOF

A large-sized pop-top roof with quality comfort mattress is a permanent feature. So there's nothing stopping you from the weekend getaway.

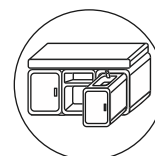

CAMPBOX KITCHEN/SLEEP

Contains everything you'll need. The practical Campbox comes in two versions for the VANSTER: in the Kitchen version with cooking and dishwashing facility, or the Sleep version with an extra bed for 2 persons.

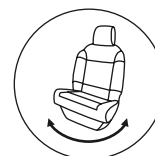

SWIVEL SEATS

The swivel, adjustable pilot seats are not just extremely comfortable, they're also great when you need to take a break and transform the interior into a living space.

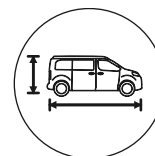

COMPACT SIZE

1.99 m* high, 1.92 m wide and 4.95 m long, the VANSTER is more manoeuvrable than practically any other bus, and can also be parked in any underground car-park.

* (height) may differ if vehicle is replated for greater weight



HIGHLIGHTS IN DETAIL



POP-TOP ROOF

POP-TOP ROOF

The VANSTER pop-top roof means you can easily set up your bed anywhere you want. The comfortable bed space (dimensions 1.90 x 1.10 m) is made for snuggling up and relaxing together.



CAMPBOX KITCHEN

Comes with practical pull-out elements, 2-burner hobs and sink. The easily insertable/removable box system transforms every VANSTER into the perfect motorhome in no time.



INDUCTION HOB

NOW YOU'LL ALWAYS BE THE CHEF DE LA CUISINE

The VANSTER is equipped with an induction hob and a 230 V CEE external socket as standard. With this, you can prepare every meal in a jiffy.



CAMPBOX MADE FROM CPL FINISHED TIMBER

A genuine alternative and is optically perfect inside the vehicle (subject to availability).



Citroën

CAMPSTER!

THE ONE FOR EVERYTHING AND EVERYBODY



Like the VANSTER, the CAMPSTER: As variable as life itself. But all told, even more tailored for the great, wide world. It truly spoils the adventurous types with its furnishings and its interior design, not forgetting the berth in the rear as standard. And thanks to

its numerous options such as the auxiliary heating system, cool box and much more besides, the CAMPSTER can be transformed into a compact, yet super comfy motorhome ready for long road trips.

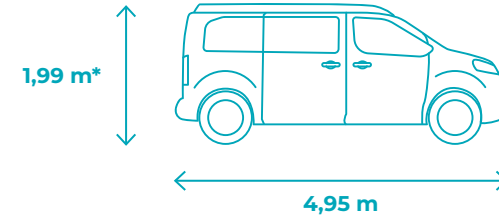

MORE DETAILS

HIGHLIGHTS

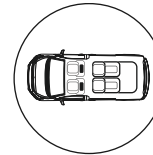

2-SEATER BENCH/BED

It's all there - with 2-seater bench/bed and flexibly adjustable single seat as standard.



PANORAMA POP-TOP ROOF

A large pop-top roof with quality comfort mattress is a permanent feature. So there's nothing stopping you from the weekend getaway.



MOBILE KITCHEN UNIT

Supplied as standard, the kitchen unit provides storage space for all your cooking utensils.

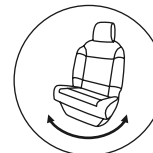

SWIVEL SEATS

The swivel, adjustable pilot seats are not just extremely comfortable, they're also great when you need to take a break and transform the interior into a living space.

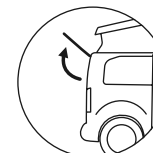

OPENING REAR-WINDOW

The separately opening rear-window means that individual items can be quickly stowed in the luggage compartment. Exceptionally practical whenever there's not enough space to open the tailgate.

* (height) may differ if vehicle is replated for greater weight

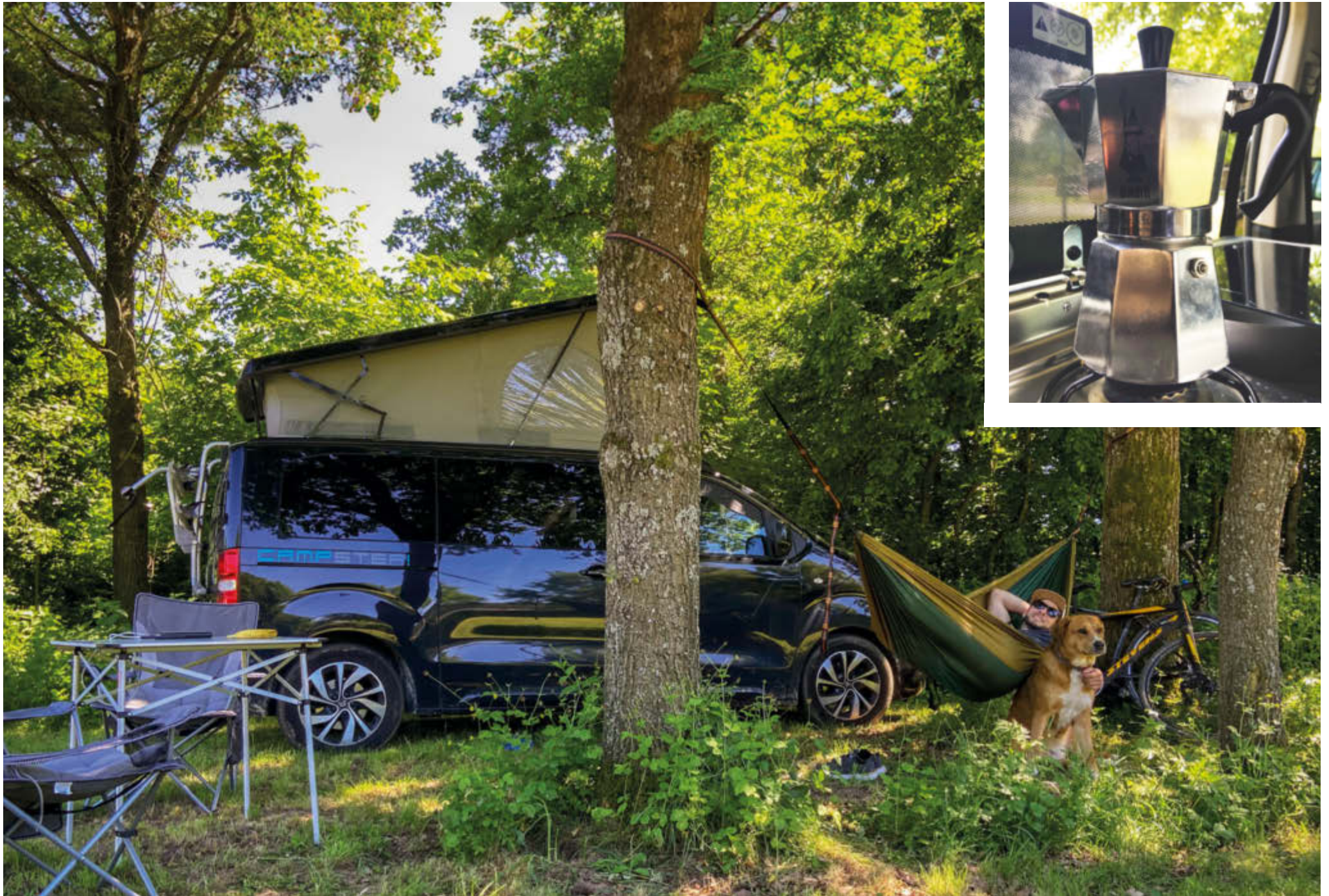

HIGHLIGHTS IN DETAIL



PANORAMA POP-TOP ROOF

SIMPLY ENJOY A GOOD NIGHT'S SLEEP

Whether up top in the raised roof with panorama window fitted as standard (bed dimensions 1,900 x 1,100 mm) or down below. That's how heavenly it is to sleep in the CAMPSTER.



More sleeping space



Practical sleeping area



Dinner for 2 – or for 3 or 4



FOLDABLE 2-SEATER BENCH/ SLEEPING BERTH

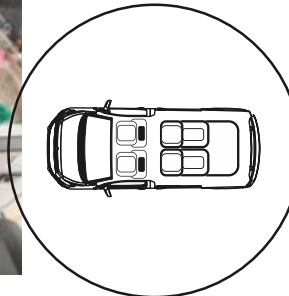

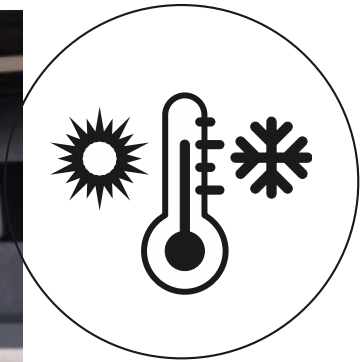

EVERYTHING AT A GLANCE

SEPARATE CONFIGURATION OPTIONS
Control panel, climate control, and auxiliary heater - easy to access, simple to use

COOKING

PRACTICAL SOLID COVER
The stainless steel sink and hob can be completely covered and combined with the inside table to create a convivial dining table.



COOLING

INTEGRATED COOLING SOLUTION
Cool-box integrated into furnishings.

BED EXTENSION

THERE'S A PLACE FOR EVERYTHING
Bed extension stowable under the bench seat. This transforms the 1.30 m x 1 m reclining space into a fully comfortable 1.90m double-bed over 1 m.



REACH FOR THE CAMPING BUS STARS

Automotive pioneer Mercedes joins forces with PÖSSL, the motorhome pioneer. With its Vito Tourer Pro and V Class models, Mercedes delivers high standards of safety, comfort and elegance. And this is the basis on which PÖSSL VANLINE's embarks on a whole new era of freedom in personalised daily and recreational mobility – VANS that can become stars?

VanSTAR

CampSTAR



■ ELEGANT EXTERIOR

The huge selection of available options means you can configure your VANSTAR and CAMPSTAR with Vito Tourer and V Class base just the way you want: Classically refined, extreme luxury, sporty elegance – what's your type?

■ TWO SLIDING DOORS

Your van is open to everything and from every side. The two large sliding doors are not merely practical, they also turn every stop into an open-air event.

■ CLEAR TO ENTER EVERY MULTI-STOREY CAR-PARK

At just 1,99 m high (height may differ if vehicle is replated for greater weight) your camping star can enter any conventional multi-storey car-park without risking frontal impact to the roof. An advantage shared by all the VANLINE models.

■ SUPERB HANDLING

Optimum driving comfort and ultimate steering precision are delivered by the series rear-wheel drive with 9G-TRONIC torque converter or the optional 4MATIC, whenever the terrain gets challenging or traction is needed on wet road surfaces. The driver can choose between "comfort", AGILITY CONTROL with selective shock-absorbing system and sports suspension for greater handling dynamics.

■ SAFE ON THE ROAD

Your VANSTAR and CAMPSTAR come with numerous safety systems as standard equipment:

- tyre pressure monitoring systems front and rear
- ECO start/stop function
- headlight levelling
- adaptive brake lights
- seat belt warning for driver and front-seat passenger
- driver and front-seat passenger airbags
- emergency brake assist
- road traffic sign recognition
- and much more ...

■ SEPARATELY OPENING REAR-WINDOW (OPTIONAL)

The separately opening rear-window means that individual items can be quickly stowed in the luggage compartment. Exceptionally practical whenever there's not enough space to open the tailgate (not available as standard; only with V Class).

■ HOME-FROM-HOME

Onboard, the comfortable onboard seat position and ultra-variable, cosy interior with up to 4 berths* below and in the roof above create a feeling of being inside your own four walls.

VANSTAR AND CAMPSTAR ARE DELIVERED PRE-EQUIPPED FOR COMFORT

- 9C-TRONIC
- aerodynamic package
- multifunction steering wheel with trip computer
- crosswind assist
- rain sensor
- highbeam assist
- immobiliser
- hill start assist
- CRUISE CONTROL
- MBUX multi-media system
- Comfort seating package
- and much more ...

LATEST GENERATION ENGINES

High-torque, efficient 4-cylinder diesel engines delivering up to 174 kW (237 PS), and which meet the Euro 6e emissions class standards. The series aerodynamic package and Blue EFFICIENCY packages additionally enhance fuel economy and reduce CO₂ emissions.

ACTIVE BRAKE ASSIST



HIGHBEAM ASSIST PLUS*



BLIND SPOT ASSIST



DISTRONIC* ACTIVE DISTANCE CONTROL ASSIST



360° CAMERA*



TRAFFIC SIGN ASSIST*



LANE DEPARTURE WARNING



* optional

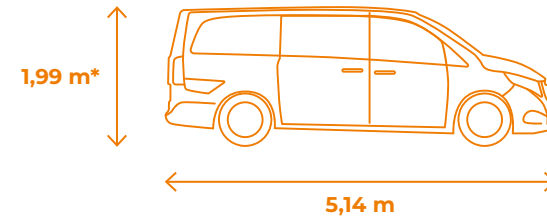

Mercedes-Benz

Vanstar

REDISCOVER YOUR WORLD



The VANSTAR is an all-round professional: Not just for joining you on every spontaneous excursion and adventure, but also as a loyal companion in your daily

life. With the VANSTAR, you are getting a fully-fledged van with camping and sleeping options on top.

HIGHLIGHTS

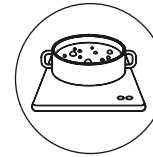

INDUCTION HOB

Flip-up induction hob in the tail garage and a 230 V CEE external socket as standard equipment.



POP-TOP ROOF

A large-sized pop-top roof with quality comfort mattress is a permanent feature. So there's nothing stopping you from the weekend getaway.

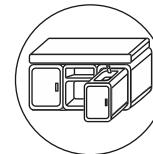

CAMPBOX KITCHEN/SLEEP

Contains everything you'll need. The practical Campbox comes in two versions: in the Kitchen version with cooking and dishwashing facility, or the Sleep version with an additional bed for 2 persons.

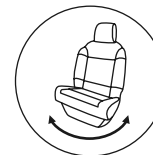

SWIVEL SEATS

The swivel, adjustable pilot seats are not just extremely comfortable, they're also great when you need to take a break and transform the interior into a living space.

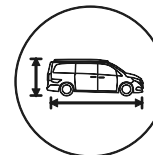

COMPACT

At 1.99 m* high, 1.93 m** wide and 5.14 m long, the VANSTAR is more manoeuvrable than practically any other bus, and can also be parked in any underground car-park.

* (height) may differ if vehicle is replated for greater weight
** excl. mirror, with mirror 2.25 m



HIGHLIGHTS IN DETAIL

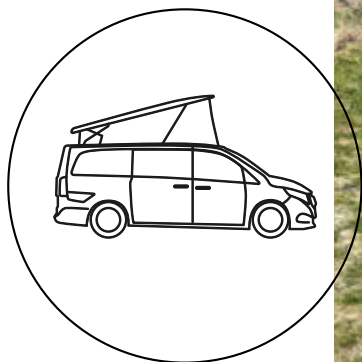

PANORAMA ROOF

SLEEPING COMFORT JUST LIKE AT HOME

You'll sleep like you do at home in our WHOOP panorama pop-top roof: with the 1.10x1.90m sized bed space, a slatted frame and the extra thick 5-cm mattress, you're guaranteed a relaxing night's sleep. The panorama function ensures a wow moment at bedtime and again in the morning – enjoyed from the comfort of your bed. The serial lighting package delivers plenty of work light below and a comfortable ambience up top - both are dimmable, of course.

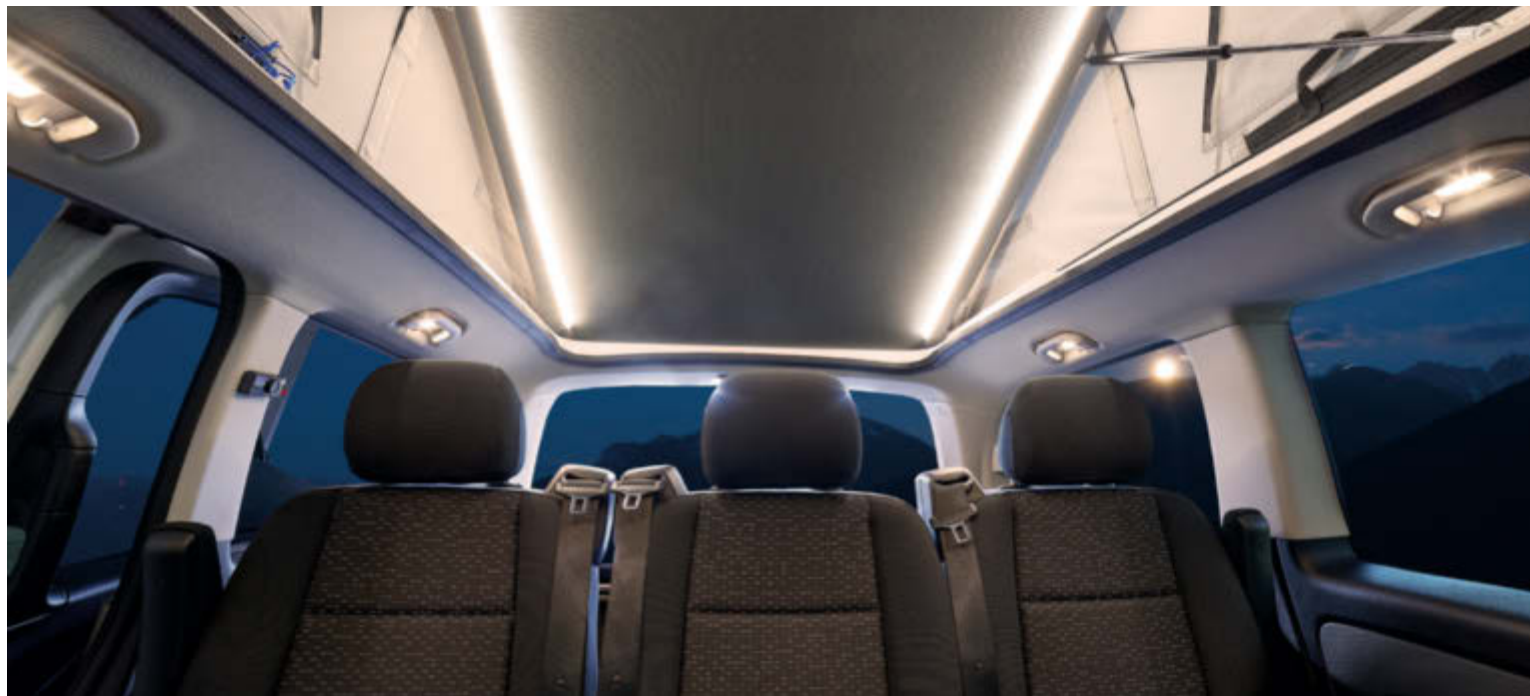

KITCHEN/SLEEP CAMP BOX

CAMPBOX KITCHEN

Comes with practical pull-out elements, 2-burner hobs and sink. The easily insertable/removable box system transforms every VANSTAR into the perfect motor-home in no time. Available as CAMPBOX KITCHEN & SLEEP with mattress.

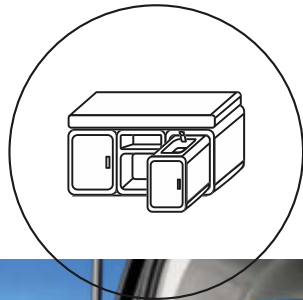

CAMPBOX LITE

With practical stackable containers, allowing the Campbox to be loaded at home. The CAMPBOX LITE KITCHEN additionally comes with a cooking and dishwashing module with fresh water and waste water tank. The CAMPBOX LITE SLEEP means you have two additional beds available. The CAMPBOX LITE KITCHEN & SLEEP offers both versions.

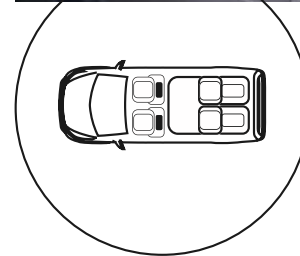

SINGLE SEATS AND BENCH

JUST THE WAY YOU WANT IT

Choose the seating you need for your daily routine. The up to 4 comfortable single seats in the V Class or a max. of two 3-person bench seats in the Vito will guarantee you a pleasant and comfortable journey.

HIGHLIGHTS IN DETAIL



HANDLES THE DAILY ROUTINE

FITS INTO EVERY GARAGE

Something you can count on. Whether you are parking your VANSTAR at home or in an underground car-park during a trip – with its compact dimensions of 1.99 m** high, 1.93 m wide and 5.14 m long, the VANSTAR will fit in no problem.

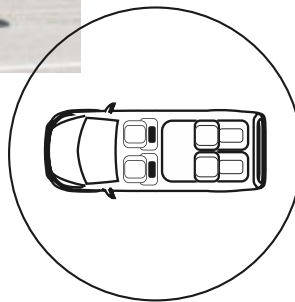

INFOTAINMENT

MBUX – THE INFOTAINMENT FROM MERCEDES IS SHAPING THE USER EXPERIENCE

This includes high-definition displays, which combine relevant driving information and central touchscreen in one control unit. Interactive elements integrate the user through voice, touch and intelligent gesture control. There are also impressive vehicle and infotainment functions as well as the possibility of arranging the user experience wholly according to personal preferences through artificial intelligence and customisation options.

* (height) may differ if vehicle is replated for greater weight



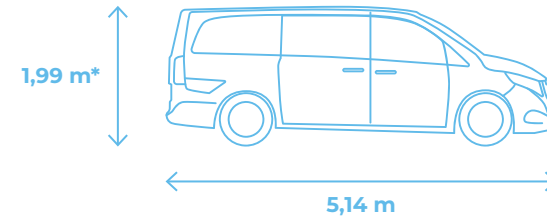

HIGHLIGHTS

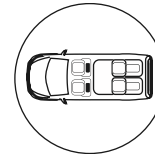

2-SEATER BENCH/BED

It's all there - with 2-seater bench/bed as standard and optional additional single seat.



PANORAMA POP-TOP ROOF

A large pop-top roof with quality comfort mattress is a permanent feature. So there's nothing stopping you from the weekend getaway.

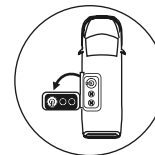

EASY MOVE KITCHEN

The last word in camper kitchen convenience. A swivel mechanism means the CAMPSTAR Easy Move Kitchen can be swung out from the vehicle with a flick of the wrist, and placed on the ground using the telescopic leg. So, you'll be ready to start cooking outdoors with the gas hobs and stainless steel basin in no time at all.

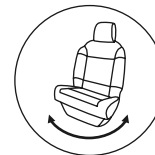

SWIVEL SEATS

The swivel, adjustable pilot seats are not just extremely comfortable, they're also great when you need to take a break and transform the interior into a living space.

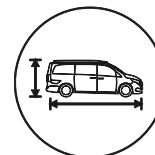

COMPACT

At 1.99 m* high, 1.93 m** wide and 5.14 m long, the CAMPSTAR is more manoeuvrable than practically any other bus, and can also be parked in any underground car-park.

Mercedes-Benz

Campstar

SURE TO DAZZLE THE EYES

A shining star in the camping bus skies. The CAMPSTAR combines the sleek elegance and dynamism of the Mercedes Vito Tourer and V Class with the familiar

innovative camping pedigree of Pössl. As a symbiosis of both these pioneers, the CAMPSTAR ticks all the boxes. See for yourself!

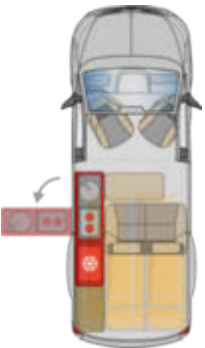

* (height) may differ, if vehicle is replated for greater weight
** excl. mirror, with mirror 2,25 m



HIGHLIGHTS IN DETAIL



2-SEATER BENCH/ SLEEPING BERTH

JUST THE WAY YOU WANT IT

The CAMPSTAR'S 2-seater bench/sleeping berth can be extended and retracted effortlessly. Enjoy convenient sleeping comfort and maximum flexibility when you're on the go. The 1.30 m x 1 m reclining space is transformed into a fully comfortable 1.90 m double-bed over 1 m.

SLEEP PEACEFULLY

At 5 cm, the extra-thick mattress in the panorama pop-up roof guarantees the best-possible sleeping comfort.

PANORAMA POP-TOP ROOF

SLEEPING COMFORT JUST LIKE AT HOME

You'll sleep like you do at home in our WHOOP panorama pop-top roof: with the 110 cm wide bed area, a slatted frame and the extra thick 5-cm mattress, you're guaranteed a relaxing night's sleep. The panorama function ensures a wow moment at bedtime and again in the morning – enjoyed from the comfort of your bed.

The serial lighting package delivers plenty of work light below and a comfortable ambience up top - both are dimmable, of course.

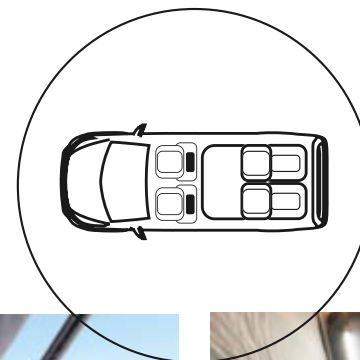



HIGHLIGHTS IN DETAIL



PLENTY OF SPACE

Generous stowage space in the locker and rear compartment.

* (height) may differ, if vehicle is replated for greater weight
** excl. mirror, with mirror 2,25 m

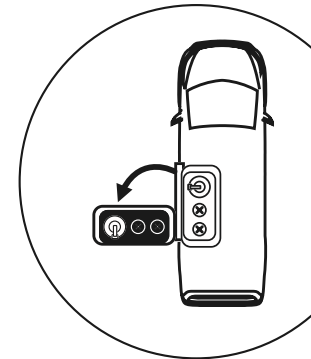

HANDLES THE DAILY ROUTINE

FITS IN EVERYWHERE – AND FITS EVERYTHING IN

You can park your CAMPSTAR at home or in an underground carpark when you're on the go – and what's more, filled with everything you might need on your trip. It's not just the compact size - 1.99 m* high, 1.93 m** wide and 5.14 m long - that's unbeatable, for the interior also boasts one of the largest usable and storage spaces in its class.

AUTHENTIC LOUNGE-STYLE COOKING

EASY MOVE KITCHEN

The undeniable highlight of the CAMPSTAR is its Easy Move Kitchen. By opening the sliding door on the kitchen side of the vehicle, the kitchen can be swivelled outwards and placed on the surface. The swivel design means that only two hand movements are needed before you can start enjoying an out-of-doors kitchen. The top quality Easy Move Kitchen comes with gas hobs, stainless steel basin, hard cover and storage facilities. Not to mention: the ambient lighting!





TOP QUALITY FURNISHINGS

The Easy Move Kitchen is made from top quality materials and is impressively easy to operate.

PRACTICAL SOLID COVER

The stainless steel basis and hob can be completely covered.





LEGAL NOTICE ON WEIGHT-RELATED INFORMATION

The weight specifications and tests for motorhomes are standardised EU-wide in the EU Implementing Regulation No 2021/535 (until June 2022: EU Implementing Regulation No. 1230/2012). The main terminology and legal rules defined in this regulation are summarised and explained for you below. You can also contact your dealer and use the PÖSSL configurator on our website for extra help with configuring your vehicle.

1. Technically permissible maximum mass

The technically permissible maximum mass of the vehicle (e.g. 3,500 kg) is a manufacturer's fixed mass specification that the vehicle may not exceed. Information on the technically permissible maximum mass of your chosen model can be found in the technical data. If the vehicle exceeds the technically permissible maximum mass in real world driving conditions, this constitutes a misdemeanour and is punishable by a fine.

2. Mass in running order

Simply put the mass in running order is the basic vehicle with standard equipment plus a legally defined average weight of 75 kg for the driver. This essentially consists of the following elements:

- the unladen weight of the vehicle together with the bodywork, including operating fluids such as lubricants, oil and coolants
- the standard equipment, i.e. all equipment items included as standard in the factory-fitted scope of delivery
- the fresh water tank filled to 100% in driving mode (drive-ready fill according to manufacturer's specifications; 20 litres) and an aluminium gas cylinder filled to 100% and weighing of 16kg;
- the fuel tank, which is 90% full with fuel;
- the driver, whose weight – regardless of the actual weight – is generally specified as 75 kg in accordance with EU law.

Information on the mass in running order for every model is available in our sales material. The important thing to know is that the mass in running order stated in the sales materials is a standard value determined during the type approval process and reviewed by the authorities. It is legally permissible, and also possible, that the mass in running order of the vehicle delivered to you will vary from the nominal value stated in the sales material. The legally permissible tolerance is $\pm 5\%$. Here the EU legislator is taking account of the fact that weight variations in supplied parts, combined with process and weather-related effects can create some fluctuation in the mass in running order. These weight variations are more easily understood by looking at a sample calculation:

- Mass in running order acc. to sales material: 2,700 kg
- Legally permissible tolerance of $\pm 5\%$: 135 kg
- Legally permissible range of the mass in running order: 2,565 kg to 2,835 kg

PÖSSL takes great efforts to reduce these weight variations to the absolute minimum, unavoidable for technical production reasons. Variances at the upper and lower end of the range are therefore very rare; however, for technical reasons they cannot be totally ruled out despite all the optimisations made. The real weight of the vehicle and compliance with the permissible tolerance is determined by weighing.

3. Mass of the passengers

The mass of the passengers is set to a default value of 75 kg for each seat provided by the manufacturer, regardless of the actual weight of the passengers. The mass of the driver is already included in the mass in running order (see no. 2 above) and is therefore not included again. In the case of a motorhome with four permitted seats, the mass of the passengers is therefore $3 \times 75 \text{ kg} = 225 \text{ kg}$.

4. Optional equipment and actual mass

According to the legal definition, optional equipment (also referred to as special equipment or optional extras) includes all optional equipment components not provided as standard which is fitted to the vehicle under the manufacturer's responsibility – i.e. ex works – and which can be ordered by the customer. Information about individual and package weights of optional equipment available to order, can be found in our sales material. For this definition, optional equipment does not include other accessories retro-fitted to the vehicle by you or the dealer after it has left the factory.

The mass of the vehicle in running order (see no. 2 above) plus the mass of the optional equipment factory-fitted to a specific vehicle add up to the actual mass. Following delivery, you will find the relevant information for your vehicle under no. 13.2 of the Certificate of Conformity (CoC). PÖSSL determines each value individually and states the weighed value in the CoC.

5. Pay-mass and minimum pay-mass

The installation of optional equipment is also subject to technical and legal limits: There is only so much optional equipment that can be ordered and factory-fitted to leave enough spare weight for luggage and other belongings (the pay-mass), without exceeding the technically permissible maximum mass. The pay-mass is calculated by subtracting the mass in running order (nominal value according to sales material, see no. 2 above), mass of the optional equipment and the mass of the passengers (see no. 3 above) from the technically permissible maximum mass (see no. 1 above). The EU regulations for motorhomes stipulates a fixed minimum pay-mass, which is the very least that must remain free for luggage and other non-factory-fitted accessories. This minimum pay-mass is calculated as follows:

Maximum pay-mass in kg $\geq 10 \times (n + L)$

Where: "n" is the maximum number of passengers plus driver and "L" is the overall length of the vehicle in metres.

For a motorhome with a length of 6 m and 4 approved seats, the minimum pay-mass is therefore e.g. $10 \text{ kg} \times (4 + 6) = 100 \text{ kg}$.

To preserve this minimum pay-mass, for every model of vehicle there is a maximum combination of optional equipment available to order. In the example shown above with a minimum pay-mass of 100 kg, the total mass of the optional equipment in a vehicle with four permitted seats and a mass in running order of 2,700 kg cannot exceed 325 kg, for example:

- 3,500 kg technically permissible total mass
- 2,700 kg mass in running order
- 3 x 75 kg mass of the passengers

- 100 kg minimum pay-mass
- = 475 kg maximum permissible mass of the optional equipment

It is important to note that this calculate is based on the standard value for the mass in running order determined in the type approval procedure, without the permissible weight variances with the mass in running order (see No. 2 above). If the maximum permissible value for the optional equipment of 325 kg (in the example) is almost or completely exhausted, an upward weight deviation can therefore result in the minimum pay-mass of 100 kg being met mathematically using the default value for the mass in running order, although in fact there is no corresponding load capacity.

To avoid this type of situation, PÖSSL is further reducing the permissible maximum weight of the total optional equipment available to order on a model-by-model basis. The limit on optional equipment is intended to ensure that the minimum pay-mass, i.e. the legally prescribed free mass for baggage and retrofitted accessories, is actually available for the vehicle load capacity of PÖSSL's delivered vehicles.

Since the weight of a specific vehicle can only be determined when it is weighed at the end of the production line, in very rare cases a situation may arise in which the minimum pay-mass at the end of the line is not guaranteed, despite the restrictions put on optional equipment. To ensure the minimum pay-mass is still met in these cases, before delivering your vehicle, PÖSSL, along with you and your dealer, will check if the vehicle might be loaded up, have the number of seats reduced, or optional equipment removed.

6. Recommendations

Production-related fluctuations in the running mass can result in variances in the load-carrying capacity. That means that the information contained in the brochure / configurator may possibly be undercut in reality. When performing the calculation, make sure you factor in the permissible tolerances, and weigh the completed vehicle before commencing your journey, in order to determine the remaining load capacity.



facebook.com/campstervanster
facebook.com/campstarvanstar



instagram.com/campster_vanster
instagram.com/campstar__vanstar



youtube.com/poesslgroup



pinterest.de/poesslgroup



linkedin.com/company/poesslgroup



**GET IN TOUCH TODAY! VISIT US ONLINE AT POESSL-VANLINE.DE, OR ON OUR SOCIAL MEDIA SITES,
OR CALL IN WITH YOUR LOCAL AUTHORISED VANLINE DEALER.**

Images: KNITTEL • danielwagnerphoto • Florian Kochinke • Klaus Bauer
Mercedes-Benz AG • Stellantis Pro One Communication

developed by papillo.de



A BRAND OF THE



Some of the details of vehicles and equipment may vary. Some of the vehicles pictured feature optional equipment available for an extra charge. Rights reserved concerning technical specifications and errors. Please note that some of the photos show decorative components, alternative designs, or optional extras that do not included in the scope of delivery, and which incur an additional charge.

*According to Directive 97/27/EC and EN 1645-2, the „mass in running order“ is the unladen weight of the vehicle with the smallest engine – incl. driver (85 kg) and filled fuel tank (56 kg), aluminium gas cylinder, cable reel and a water tank that is 20% full. The gross vehicle weight must not be exceeded when the personal equipment, persons travelling with the vehicle and any optional extras are taken into account. Installation of extras will reduce the maximum recommended load and may reduce the permitted number of persons. The information on the scope of delivery, appearance, performance, dimensions and weight of the vehicles corresponds to the knowledge available at the time of going to press, and the European homologation regulations. These can change up until the time the vehicle is purchased or until delivery. Deviations within the factory tolerances (+/- 5% max.) are possible and permissible.