

Congratulations

We congratulate you on your new motorhome and would like to thank you for choosing a quality product from our company.

Whatever journey you want to take - with a Summit, Summit Prime and Summit Shine motorhome you always have the right companion for every trip: Whether for a city trip, a short excursion or your family holidays. The innovative and well-planned layouts offer a wide range of possibilities and the modern interior design, which is common to all models, immediately convey a homely flair. The high quality standard and the large variability furthermore enthrall - lack of space is a thing of the past in our vehicles. Many useful details prove to be extremely practical when on the road making your holiday even more relaxed.

Every Summit, Summit Prime and Summit Shine motorhome is manufactured with real care and quality is closely checked. This ensures that our products have a long service life.

This instruction manual deals primarily with the aspect of living in your motorhome. It will give you all important information and tips so that you can enjoy all technical advantages of your motorhome to the full. We have also included a chapter on maintenance - and thus on the conservation of value.

In addition, you will find the documents on the base vehicle and the various built-in appliances.

For maintenance work or whenever you need some help, please always get in touch with your authorised dealer. They know your caravan best of all and will meet all your requests fast and reliably.

We wish you a lot of fun with your motorhome, a relaxing holiday and safe driving at all times.

1	Records	5	7.1.2	Cap for the fresh water filler neck	29
1.1	Vehicle document	5	7.2	Ventilation	29
1.2	Warranty	5	7.3	Windows	30
1.3	Inspection records	6	7.3.1	Windows living area	31
1.4	Inspection plan	7	7.3.2	Hinged window with automatic hinges .	32
2	Introduction	8	7.3.3	Hinged window with damping	33
2.1	General	9	7.3.4	Blind and roller insect screen	34
2.2	Environmental tips	9	7.3.5	Roman shades for driver's window and front passenger's window	34
3	Safety	11	7.3.6	Roman shade windscreen	35
3.1	Fire prevention	11	7.4	Sliding door	36
3.1.1	Avoidance of fire risks	11	7.4.1	Sliding door, electric	36
3.1.2	Fire-fighting	11	7.4.2	Obstacle detection function	37
3.1.3	In case of fire	11	7.4.3	Emergency unlocking mechanism of the electrical sliding door	38
3.2	General	12	7.4.4	Power closing aid	39
3.3	Road safety	13	7.4.5	Insect screen at the sliding door	40
3.4	Towing	14	7.5	Skylights and SkyRoof®	41
3.5	Gas system	14	7.5.1	Hinged skylight	42
3.5.1	General information	14	7.6	Wind-up skylight and SkyRoof®	43
3.5.2	Gas bottles	16	7.7	Multiroof (optional)	44
3.6	Electrical system	16	7.8	Locking mechanism of the cupboard doors	45
3.6.1	Emergency generator	16	7.9	Table	45
3.7	Water system	17	7.9.1	Swivel table (optional)	45
3.8	Using the beds	17	7.9.2	Suspension table with tray (optional) .	46
4	Before the journey	18	7.10	Sockets living area	47
4.1	Payload	18	7.11	Lamps	47
4.1.1	Terms	18	7.12	Beds	48
4.1.2	Calculating the payload	19	7.12.1	Bed in the pop-up roof	48
4.1.3	Loading the vehicle correctly	20	7.13	Additional seat	50
4.2	Entrance step	21	7.13.1	Set up additional seating	50
4.2.1	Electrically operated entrance step . .	21	7.13.2	Stow additional seat	51
4.3	Road safety	22	8	Gas system	52
4.4	Spare key	23	8.1	General	52
5	During the journey	24	8.2	Gas bottles	53
5.1	Driving the motorhome	24	8.3	Changing gas bottles	54
5.2	Driving speed	24	8.4	Gas isolator taps	55
5.3	Seat belts	25	8.5	Configuration of the gas bottle in the gas bottle compartment during driving .	55
5.3.1	Using the seat belt correctly	25	9	Electrical system	56
5.4	Driver's seat and front passenger's seat .	25	9.1	General safety instructions	56
5.5	Seating arrangement	26	9.2	12 V power supply	56
5.6	External doors	26	9.2.1	Living area battery	57
5.7	Filling up with diesel	26	9.3	Charging unit/booster	58
6	Vehicle set-up	27	9.3.1	Charging using a 230 V power supply .	58
6.1	Handbrake	27	9.3.2	Charging using the vehicle engine . . .	58
6.2	Entrance step	27	9.3.3	Charging management settings for battery replacements	59
6.3	230 V connection	27	9.4	Fuses	60
6.4	Refrigerator	27	9.4.1	12 V fuses	60
6.4.1	Compressor refrigerator	27	9.4.2	12 Volt fuses for appliances	61
7	Living	28	9.4.3	230 V combination automatic circuit breaker	62
7.1	External flaps	28	9.5	Control panel D100	63
7.1.1	Flap for 230 V connection, square . . .	28			

Table of contents

9.5.1	Charging mode	64	12.1.2	Washing the vehicle	93
9.5.2	Control panel lighting brightness	64	12.1.3	Windows of acrylic glass	94
9.5.3	Night mode.	64	12.1.4	Waste water tank	94
9.5.4	Warnings	65	12.1.5	Fresh water tank.	94
9.6	Control panel D110	67	12.1.6	Entrance step	94
9.6.1	Charging mode	68	12.1.7	Cleaning and care of the external synthetic parts	95
9.6.2	Control panel lighting brightness	68	12.1.8	Relieving the Skyroofs ® rubber seal	95
9.6.3	Night mode.	68	12.2	Interior care	95
9.6.4	Warnings for the starter and living area battery	69	12.3	Winter care	96
9.7	Control panel D200	70	12.3.1	Winter operation	97
9.7.1	Setting the time in the control display	72	12.4	Lay-up.	98
9.7.2	Charging mode	72	12.4.1	Temporary lay-up	98
9.7.3	Control panel lighting brightness	73	12.4.2	Winter lay-up	99
9.7.4	Night mode.	73	12.4.3	Starting up the vehicle after a temporary lay-up or after lay-up over winter	100
9.7.5	Warnings	73	13	Maintenance	101
9.7.6	Fresh water and waste water tank.	74	13.1	Official inspections	101
9.7.7	Living area and starter battery.	75	13.2	Inspection work.	101
9.8	Control panel D201	76	13.3	Maintenance work	101
9.8.1	Setting the time in the control display	77	13.4	Replacing lamps.	102
9.8.2	Charging mode	78	13.5	Spare parts	102
9.8.3	Control panel lighting brightness	78	13.6	Vehicle identification plate	103
9.8.4	Night mode.	78	13.7	Warning and information stickers	103
9.8.5	Warnings for the starter and living area battery	79	14	Troubleshooting	104
10	Appliances	80	14.1	Electrical system.	104
10.1	General	80	14.2	Gas system.	105
10.2	Heater	80	14.3	Cooker	106
10.2.1	To heat properly.	81	14.4	Heater/Boiler.	106
10.2.2	Truma Combi hot-air heater.	81	14.5	Refrigerator.	107
10.3	Boiler	82	14.6	Water supply.	108
10.3.1	Safety/drainage valve	82	14.7	Body	109
10.3.2	Filling/emptying the boiler	83			
10.4	Gas cooker.	83			
10.5	Refrigerator	84			
11	Sanitary fittings	85			
11.1	Water supply, general	85			
11.2	Emptying the water system	85			
11.2.1	Emptying the fresh water tank	85			
11.2.2	Emptying the waste water tank	87			
11.2.3	Waste water tank with electric ball valve (optional).	87			
11.2.4	Filling the fresh water tank.	88			
11.3	Starting up the water supply	89			
11.4	Water system.	89			
11.4.1	Winter package (special equipment)	89			
11.5	Cassette toilet	90			
11.5.1	Commissioning the cassette toilet	90			
11.5.2	Operation of the cassette toilet	90			
11.5.3	Using the toilet in winter.	91			
11.6	Bathroom unit / toilet usage	92			
12	Care	93			
12.1	External care	93			
12.1.1	Washing with a high-pressure cleaner.	93			

1.3 Inspection records

Delivery

Date:

Signature and stamp of the H-Line Produktion GmbH dealer:

1th year

Date:

Signature and stamp of the H-Line Produktion GmbH dealer:

- No defects found
- Found defects:

Should it be determined during an inspection that additional work is necessary, then the carrying out of this work is dependent on the customer commissioning this to be done. Please also adhere to the service intervals stipulated by the manufacturers of the individual equipment. Information is included in the service documents enclosed.

If the inspections specified by the manufacturer are not observed, the guarantee can lapse with reservation.

1.4 Inspection plan

Pos.	Component	Activity	Interval
1	Joints, hinges	Lubricate	Annually
2	Refrigerator, heater, boiler, cooker, lighting, storage flap and door closures, toilet, seat belts	Function check	Annually
3	Windows, skylights	Function check, water ingress test	Annually
4	Upholstery, curtains, blinds	Visual check	Annually
5	Sealing strips, edges, -rubber	Check for damage	Annually
6	Water supply	Water ingress test	Annually
7	Hot-air system	Function check, clean fan wheel if necessary	Annually
8	Underbody protection, fastening of the underbody attachments	Visual check	Annually
9	Electrical system	Function check	Annually
10	Gas system	Official gas inspection	Every two years
	- Gas filter	Replace gas filter cartridge	Every two years
11	Underbody	Visual check, repair underbody protection if necessary	Every two years

We reserve the right to modify the inspection plan.

Please read this instruction manual completely before using the vehicle for the first time!

Always keep this instruction manual in the vehicle. Also inform all other users of the safety regulations.



- ▶ The non-observance of this symbol can lead to personal injury.



- ▷ The non-observance of this symbol can lead to damage being caused to, or inside the vehicle.



- ▷ This symbol indicates recommendations or special aspects.



- ▷ This symbol indicates actions which lead to environmental awareness.

This instruction manual contains sections which describe model-specific equipment or special equipment. These sections are not specially marked. It may be that your vehicle has not been fitted with this special equipment. In some cases, the actual equipment of your vehicle may therefore be different from that shown in some illustrations and descriptions.

However, your vehicle may be fitted with other special equipment not described in this instruction manual.

Special equipment is described when an explanation is required.

Adhere to the instruction manuals which are separately enclosed.



- ▷ The details "right", "left", "front" and "rear" always refer to the vehicle in direction of travel.
- ▷ All dimensions and weight details are "approximate".

Should the vehicle be subjected to damage due to a failure to follow the instructions in this instruction manual, then the warranty claim is deemed invalid.

Our vehicles are subjected to continuous development. Please understand that we reserve the right to alter the form, equipment and technology. Therefore, no claims can be made against the manufacturer as a result of the contents of this instruction manual. The equipment which was known and included at the time of going to press is described.

The reprinting, translation and copying, including extracts is not permitted without prior written authorisation from the manufacturer.

2.1 General

The vehicle is constructed in accordance with the latest technology and the recognised safety regulations. Nevertheless, personal injury may result and the vehicle may be damaged if the safety instructions in this instruction manual are not followed.

Depending on the configuration, the first-aid kit and hazard warning triangle are not included as standard. Equip the vehicle with a first-aid kit and hazard warning triangle before using it for the first time. In case of vehicles with a gross weight exceeding 3.5 t a flashing hazard warning light has to be carried additionally on the vehicle.

Only use the vehicle in a technically impeccable condition. Follow the instructions in the instruction manual.

Malfunctions which impair the safety of persons or the vehicle should be immediately remedied by qualified personnel. To avoid further damages, observe the duty to avert, minimise or mitigate loss for the user during faults. Have the vehicle's braking and gas systems inspected and repaired by an authorised specialist workshop only.

Alterations to the body are only to be carried out with the authorisation of the manufacturer.

The vehicle is designed for the exclusive transport of persons. Luggage and accessories may only be transported up to the maximum permissible gross weight.

Observe the test and inspection periods stipulated by the manufacturer.

2.2 Environmental tips



- ▷ Do not impair the tranquillity and spruceness of nature.
- ▷ Remember that: All kinds of waste water and household waste are not to be disposed of in drains or in the open countryside.
- ▷ Only empty the waste water tank and toilet cassette or sewage tank at disposal stations at the camping or caravan sites, which are especially provided for this purpose. When stopping in towns and communities, observe the instructions at caravan sites or ask where there are disposal stations.
- ▷ Collect waste water on board only in the waste water tank or, if need be, in other vessels suitable to this purpose.
- ▷ Empty waste water tank as often as possible, even when it is not completely full (hygiene).
If possible, flush out waste water tank and, if necessary, drainage pipe with fresh water every time it is emptied.
- ▷ Never allow the toilet cassette or sewage tank to become too full. Empty the toilet cassette or sewage tank frequently, at the latest as soon as the level indicator lights up.
- ▷ Separate household waste according to glass, tin cans, plastic and wet waste also when on a journey. Enquire at the town or community authority about disposal points. Household waste is not to be disposed of in waste paper baskets which are situated at car parks.
- ▷ Empty waste bins as often as possible into the cans or containers that are provided for this purpose. This helps to avoid unpleasant smells and an accumulation of rubbish on board.



- ▷ When parked, do not allow the engine to run more than necessary. When running idle, a cold engine releases more contaminants than usual. The running temperature of the engine is achieved more quickly whilst the vehicle is in motion.
- ▷ Use an environmentally-friendly WC chemical agent for the WC which can also be biologically degraded and only use small doses.
- ▷ When staying in towns and communities for longer periods, search for parking areas which are especially designated for motorhomes. Enquire at the town or community authority about parking spaces.
- ▷ Always leave the parking places in a clean condition.

3.1 Fire prevention

3.1.1 Avoidance of fire risks



- ▶ Never leave children in the vehicle unattended.
- ▶ Keep flammable materials clear of heating and cooking appliances.
- ▶ Lights can get very hot. When the light is switched on, a safety distance of 30 cm to combustible material has to be maintained. Fire hazard!
- ▶ Never use portable heating or cooking appliances.
- ▶ Only authorised qualified personnel may modify the electrical system, the gas system or the appliances.

3.1.2 Fire-fighting



- ▶ Always carry a dry powder fire extinguisher in the vehicle. The fire extinguisher must be approved, tested and close at hand.
- ▶ Have the fire extinguisher tested at regular intervals by authorised qualified personnel. Observe the date of testing.
- ▶ The fire extinguisher is not included in the scope of delivery.
- ▶ Always keep a fire blanket at hand near the cooker.

3.1.3 In case of fire



- ▶ Evacuate all passengers.
- ▶ Cut off the electrical power supply and disconnect from the mains.
- ▶ Close regulator tap on the gas bottle.
- ▶ Sound the alarm and call the fire brigade.
- ▶ Fight the fire if this is possible without risk.



- ▷ Keep escape routes clear.
- ▷ Observe the fire extinguisher instructions for use.

3.2 General



- ▶ The oxygen in the vehicle interior is used up by breathing and the use of gas operated appliances. That is why the oxygen needs to be replaced on a constant basis. For this purpose, forced ventilation options (e.g. skylights with forced ventilation, mushroom-shaped vents or floor vents) are fitted to the vehicle. Never cover or block forced ventilations from the inside or outside with objects such as e.g. a winter mat. Keep forced ventilations clear of snow and leaves. There is a danger of suffocation due to increased CO₂ levels.
- ▶ Observe the headroom of the doors.
- ▶ Gas lines and electrical cables are laid in the floor. Never drill holes or screw screws into the floor. There is danger of a gas explosion or of a power cut or short circuit due to damage to a line or cable.



- ▷ As far as the fitted appliances (heater, cooker, refrigerator, etc.) and the base vehicle (engine, brakes, etc.) are concerned, the instruction manuals are authoritative. It is imperative that they be observed.
- ▷ Fitting accessories or special equipment can alter the dimensions, weight and road behaviour of the vehicle. Some of the parts must be entered in the vehicle papers.
- ▷ Only use wheel rims and tyres which are approved for the vehicle. Information concerning the size of the approved wheel rims and tyres is included in the vehicle documents or can be obtained from authorised dealers and service centres.
- ▷ Firmly apply the handbrake when parking the vehicle.
- ▷ Do not step on or stand on the motorhome roof. Avoid point loads. The maximal roof load is specified in the vehicle documents.



- ▷ When leaving the vehicle, it is imperative that all doors, external flaps and windows are closed.
- ▷ Hazard warning triangle and first-aid kit conforming to DIN 13164 are prescribed by law and must be carried on the vehicle.
- ▷ Only move the vehicle on the road if the driver has a driver's license valid for the vehicle class.
- ▷ When selling the vehicle, hand over all instruction manuals for the vehicle and the fitted appliances.

3.3 Road safety



- ▶ Before commencing the journey, carry out a functional check of indicating and lighting equipment, the steering and the brakes.
- ▶ If the vehicle has been stationary for a long period (approx. 10 months) have the braking and gas systems checked by an authorised specialist workshop.
- ▶ Before starting the journey and also after short breaks check whether the entrance step has been retracted completely.
- ▶ Fold in the pop-up roof fully and lock it into place before commencing the journey.
- ▶ Before commencing the journey, open and secure the shades on the windscreen and on the driver's and front passenger's windows.
- ▶ Before starting the journey, rotate the seat in the direction of travel and lock in position. The rotating seats must remain locked in the direction of travel during the journey.
- ▶ Before starting your journey, remove the television (if existing) from the support and store it securely.
- ▶ During the journey, persons are only to sit on the permitted seats (see Chapter 5). The authorised number of seats is stipulated in the vehicle documents.
- ▶ Before starting the journey fasten your seat belt and keep it fastened during the journey.
- ▶ Always secure children with the child-protection equipment that is mandatory for the respective child's size and weight.
- ▶ Factory-set three-point safety belts must be used when attaching child restraint systems.
- ▶ The base vehicle is a commercial vehicle (small truck). Adapt your manner of driving correspondingly.
- ▶ Observe the overall height of the vehicle (including roof loads) at underpasses, tunnels, etc.
- ▶ Always take the increased susceptibility to side winds arising from the vehicle height.
- ▶ In winter, the roof must be free of snow and ice before commencing the journey.



- ▷ Before commencing the journey, distribute the vehicle payload evenly (see Chapter 4).
- ▷ When loading the vehicle and when taking a rest from driving, in order to load luggage or food, for example, observe the maximum permissible gross weight and axle loads (refer to vehicle documents).
- ▷ Before commencing the journey, ensure that all cupboard doors, the toilet door and all drawers and flaps are secure. Engage the refrigerator door securing device. Lock the folding wall of the toilet compartment. Fold up the supplementary supports (special equipment) and lock them.
- ▷ Before commencing the journey, close windows and skylights.
- ▷ Before commencing the journey, close all external flaps and lock them.
- ▷ Use wheel chocks at uphill and downhill.

3.4 Towing



- ▶ Care is to be taken when connecting and detaching a trailer. Risk of accident and injury!
- ▶ No persons are to be between the towing vehicle and the trailer during positioning for connecting and detaching.

3.5 Gas system

3.5.1 General information



- ▶ Close all gas isolator taps and the regulator tap before commencing the journey and when leaving the vehicle.
- ▶ No appliance (e.g. heating or refrigerator) that is operated through the built-in burner may be operational while fuel is being filled up, on ferries or in the garage. Danger of explosion!
- ▶ If an appliance is operated through a burner, do not start the appliance up in closed areas (e.g. garages). Danger of poisoning and suffocation!
- ▶ Have the gas system serviced, repaired or altered by an authorised workshop only.
- ▶ Have the gas system checked by an authorised specialist workshop before starting up and according to the national regulations. This also applies for not registered vehicles. For modifications to the gas system have the gas system immediately checked by an authorised specialist workshop.
- ▶ The gas pressure regulator and the exhaust gas pipes also have to be checked. The gas pressure regulator has to be replaced at least every 10 years. The vehicle owner is responsible for seeing that this is carried out.
- ▶ In case of a defect of the gas system (gas odour, high gas consumption) there is danger of explosion! Close the regulator tap on the gas bottle immediately. Open doors and windows and ventilate well.
- ▶ In case of a defect in the gas system: Do not smoke; do not ignite any open flames, and do not operate electric switches (light switches etc.).
- ▶ Have the defect in the gas system repaired by an authorised specialist workshop.
- ▶ Open a skylight or a window before taking open sources of combustion (gas cooker) into service.
- ▶ Do not use the gas cooker or gas oven for heating purposes.
- ▶ If the vehicle or gas devices are not used, close the regulator tap on the gas bottle.
- ▶ If there are several gas devices, each gas device must have its own gas isolator tap. If individual gas devices are not in use, close the respective gas isolator tap.
- ▶ Ignition safety valves must close within 1 minute after the gas flame has extinguished. A clicking sound is audible. Check function from time to time.
- ▶ The installed gas appliances are designed for use solely with propane or butane gas or a mixture of both. The gas pressure regulator as well as all installed gas devices are set for a gas pressure of 30 mbar.



- ▶ When gas appliances are switched on where the operating knob has to be pressed in for ignition (e.g. gas cooker), this has to spring back by itself when it is released.
- ▶ Propane gas is capable of gasification up to $-42\text{ }^{\circ}\text{C}$, whereas butane gas gasifies at $0\text{ }^{\circ}\text{C}$. Below these temperatures no gas pressure is available. Butane gas is unsuitable for use in winter.
- ▶ Regularly inspect the gas tube fitted to the gas bottle connection for tightness. The gas tube must not have any tears and must not be porous. Have the gas tube replaced by an authorised specialist workshop no later than 10 years after the manufacturing date. The operator of the gas system must see to it that the parts are replaced.
- ▶ Due to its function and construction, the gas bottle compartment is a space which is open to the exterior. Never cover or block the standard forced ventilation. Otherwise leaking gas cannot be dispersed to the outside.
- ▶ Do not use the gas bottle compartment as storage space as it is not moisture-proof.
- ▶ Secure the gas bottle compartment in order to prevent unauthorised persons opening it. To do so lock the access.
- ▶ The regulator tap on the gas bottle must be accessible.
- ▶ Only connect gas-operated devices (e.g. gas grill) which have been designed for a gas pressure of 30 mbar.
- ▶ The exhaust gas pipe must be fitted tightly to the heating system and to the vent and must be sealed. The exhaust gas pipe must not show any evidence of damage.
- ▶ Exhaust fumes must be able to escape into the atmosphere unhindered and fresh air must be able to enter unhindered. Therefore keep the waste gas vents and intake openings clean and free (e.g. of snow and ice). No snow walls or aprons may be allowed to lie against the vehicle.
- ▶ The exhaust gas system of the gas heater must be routed along its entire length and must be mounted firmly with clamps (if necessary with exhaust gas supports).
- ▶ Faults can occur when igniting gas at altitudes exceeding 1.000 m above sea level. This is not a malfunction of the appliance.

3.5.2 Gas bottles



- ▶ Gas bottles are only to be transported within the designated gas bottle compartment.
- ▶ Place gas bottles vertically in the gas bottle compartment.
- ▶ Tie down gas bottles so that they are unable to turn or tilt.
- ▶ If the gas bottles are not connected to the gas tube, always place the protective cap on top.
- ▶ Close the regulator tap on the gas bottle before the gas pressure regulator or gas tube are removed from the gas bottle.
- ▶ Use your hands only to connect the gas pressure regulator or the gas tube to the gas bottles. Do not use any tools.
- ▶ Only use special gas pressure regulators with a safety valve designed for vehicle use. Other gas pressure regulators are not permitted and cannot meet the demanding requirements.
- ▶ Use only 11 kg or 5 kg gas bottles. Camping gas bottles with a built-in reflux valve (blue bottle with max. 2.5 or 3 kg content) are permitted in exceptional cases with a safety valve.
- ▶ Never block the ventilation openings in the floor under the gas bottles.

3.6 Electrical system



- ▶ Only allow qualified personnel to work on the electrical system.
- ▶ Prior to carrying out work on the electrical system, switch off all devices and lights, disconnect the battery and disconnect the vehicle from the mains.
- ▶ Only use original fuses with the stipulated values.
- ▶ Only replace defective fuses when the cause of the defect is known and has been remedied.
- ▶ Never bridge or repair fuses.

3.6.1 Emergency generator



- ▷ Avoid voltage fluctuations when operating the emergency generator, since the electronic equipment can be damaged. Circuit an overvoltage protection before the charging unit.
- ▷ When using an emergency generator observe the specifications of the manufacturer.

3.7 Water system



- ▶ Water left standing in the water tank or in the water pipes becomes undrinkable after a short period. For this reason, rinse the water pipes and the water tank thoroughly with several litres of fresh water before each use of the vehicle. To do this, open all water taps. After each use of the vehicle completely empty the water tank and the water pipes.



- ▷ If the vehicle is not used for several days or if it is not heated when there is a risk of frost, empty the entire water system. Leave the water taps on in central position. Leave the safety/drainage valve (if available) and all drain cocks open. Frost damage to appliances, frost damage to the vehicle and deposits in water-carrying components can be avoided in this way.

3.8 Using the beds



- ▷ Never exceed the maximum load of the beds:
Single beds (per sleeping place): 100 kg
Pop-up roof (total): 200 kg

4.1 Payload



- ▶ Excessive payload and the wrong tyre pressure can cause the tyre to burst. You can lose control of the vehicle.
- ▶ Adapt your speed to the payload. The stopping distance is longer when the payload is higher.



- ▷ The maximum permissible gross weight stated in the vehicle documents is not to be exceeded by the payload.
- ▷ Built-in accessories and special equipment reduce the payload.
- ▷ Adhere to the axle load stated in the vehicle documents.

On loading, make sure that the payload's centre of gravity is as low as possible (directly above the floor of the vehicle). Otherwise this may affect the driving characteristics of the vehicle.

4.1.1 Terms



- ▷ In technical and scientific texts the term "mass" has replaced the term "weight". However the term "weight" is still the more common term in general usage. To contribute toward understanding the term "mass" is therefore only used in established phrases in the following passages.

Maximum permissible gross weight in a laden condition

The maximum permissible gross weight in a laden condition is the weight that a vehicle may never exceed.

The maximum permissible overall weight in laden condition consists of the **mass in ready-to-drive condition** and of the **payload**.

The manufacturer has specified the maximum permissible gross weight in a laden condition in Field F.1 of the vehicle documents.

Mass in ready-to-drive condition

The manufacturer specifies the mass in ready-to-drive conditions in Field G of the vehicle documents.

Payload

The payload is made up as follows:

- Conventional load
- Additional equipment
- Personal equipment

Explanations of the individual components of the payload are contained in the following text.

Conventional load

The conventional load is the weight specified by the manufacturer for the passengers.

Conventional load means: 75 kg are calculated for every seat specified by the manufacturer, regardless of how much the passengers actually weigh. The driver's seat is already included as part of the mass in ready-to-drive condition and must **not** be calculated as part of the conventional load.

The manufacturer specifies the number of seats in Field S.1 of the vehicle documents.

Additional equipment Additional equipment includes accessories and special equipment. Examples of additional equipment include:

- Tow coupling
- Roof racks
- Awning
- Bike or motorcycle rack
- Satellite unit

Information about the weights of the various special equipment devices can be obtained from the manufacturer.

Personal equipment Personal equipment includes all items in the vehicle that are not included in the conventional load and the additional equipment. For example, personal equipment can include the following:

- Foodstuffs
- Crockery
- Television
- Radio
- Clothes
- Bedding
- Toys
- Books
- Toiletries

No matter where kept, personal equipment also includes:

- Animals
- Bikes
- Boats
- Surfboards
- Sports equipment

4.1.2 Calculating the payload



- ▶ Payload calculation at the manufacturer is partly based on all-inclusive weights. For safety reasons, the maximum permissible gross weight in a laden condition must not be exceeded.
- ▶ Only the maximum permissible gross weight and the mass in a ready-to-drive condition, not the actual weight of the vehicle, is stated in the vehicle documents. For your own safety, we recommend that you have your loaded vehicle (with passengers) weighed on a public weighbridge before you set out on your journey.

The payload is the difference in weight between

- Maximum permissible gross weight in a laden condition and
- Vehicle mass complete in a ready-to-drive condition.

Example for calculating the payload

	mass in kg to be calculated	Calculation
Maximum permissible gross weight according to vehicle documents, Field F.1	3300	
Vehicle mass in a ready-to-drive condition, including basic equipment according to Certificate of Conformity (CoC) Point 13.2, actual weight	- 2720	
This results in a permissible payload of	580	
Conventional load, e.g. 3 persons at 75 kg each	- 225	
Additional equipment	- 40	
For the personal equipment this results in	= 315	

The calculation of the payload from the difference between the maximum permissible gross weight in laden condition and the mass specified by the manufacturer in ready-to-drive condition is however only a theoretical value.

Only if the vehicle is weighed with full tanks (fuel and water), full gas bottles and complete additional equipment on a public weighbridge, can the actual payload be determined.

4.1.3 Loading the vehicle correctly



- ▶ To ensure safety never exceed the maximum permissible gross weight in a laden condition.
- ▶ Distribute the load evenly between the left-hand and right-hand sides of the vehicle.
- ▶ Distribute the load evenly between both axles. Observe the axle loads specified in the vehicle documents. Additionally observe the permissible load-carrying capacity of the tyres.
- ▶ Securely store all the objects so that they cannot slide or slip.
- ▶ Store heavy objects (awning, canned food, etc.) close to the axles. Low-lying storage compartments whose doors do not open in the direction of travel are particularly suited for storing heavy objects.
- ▶ Store lighter objects (laundry) in the roof storage compartments.

4.2 Entrance step



- ▶ Before starting the journey and also after short breaks check whether the entrance step has been retracted completely.
- ▶ Do not stand in the direct range of movement of the entrance step while the entrance step is being extended or retracted.
- ▶ Do not step on the entrance step until it has extended completely. There is a risk of injury!
- ▶ Never raise or lower persons or loads with the entrance step.



- ▷ Clean dust and dirt regularly from the entrance step, do not grease or oil moving parts.

4.2.1 Electrically operated entrance step

Operating switch

The switch to operate the entrance step is located on the inside of the vehicle in the area of the conversion door.

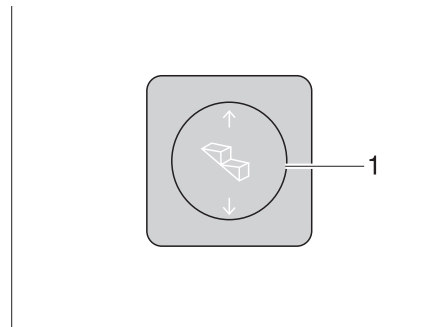

Fig. 1 Operating switch entrance step

Extending: ■ Press the rocker switch (Fig. 1, 1) down until the entrance step has extended completely.

Retracting: ■ Press the rocker switch (Fig. 1, 1) up until the entrance step has retracted completely.

Fuses

The fuse for the entrance step is located at the entry of the sliding door (on the right behind the light in the entry area). In the case of a malfunction of the entrance step the light can be levered out with a suitable tool and subsequently the fuse replaced.

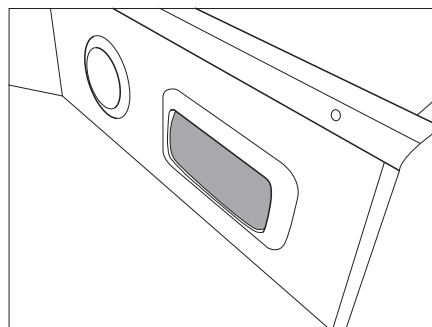

Fig. 2 Entry light living area

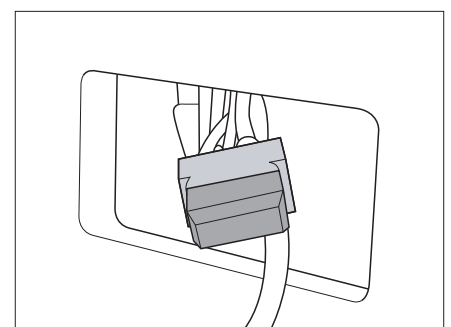

Fig. 3 Fuse entrance step (20 A)

4.3 Road safety



- ▶ Check the tyre pressure before a journey and at 2-week intervals. Wrong tyre pressure causes excessive wear and can lead to damage or even to tyre burst. You can lose control of the vehicle.

Before commencing the journey, work through the checklist:

No.	Checks	checked
Base vehicle		
1	All vehicle documents are on board	
2	Tyres in proper condition	
3	Vehicle lighting, brake and reversing lights function	
4	Oil level at engine, gear unit and power steering checked	
5	Coolant and liquid for windshield washer system topped up	
6	Breaks function	
7	Brakes react evenly	
8	When braking, the vehicle remains on track	
9	Complete set of reserve keys is included	
Housing body, outside		
10	Awning completely retracted	
11	Roof free of snow and ice (in winter)	
12	External connections and lines disconnected and stored away	
13	Pop-up roof folded in	
14	Entrance step retracted	
15	External flaps and doors closed and locked	
16	Overall height of the vehicle including roof rack when loaded measured and noted. Keep the height information close at hand in the driver's cabin	
Housing body, inside		
17	Windows and skylights closed and locked	
18	Television securely stored (if one is built in)	
19	Television antenna retracted (if one is built in)	
20	Loose parts stored away or fixed in position	
21	Open storage spaces empty	
22	Refrigerator door secured	
23	Refrigerator set to 12 V operation	
24	All drawers and flaps closed	
25	Living area doors secured	
26	Permissible gross weight of the motorhome not exceeded	
27	Children's seats mounted to seats with three-point safety belts	
28	Swivel seat locking device for driver's seat and front passenger's seat locked	
29	Curtains hooked into the retaining clips	
30	Shades in the driver's cabin opened and secured	

No.	Checks	checked
31	Table and sink cover securely stored (e.g. rear storage compartment)	
32	Water tank filled sufficiently	
33	All the water tapping points as well as kitchen, bath, shower, and toilet checked for leakage	

Gas system

34	Gas bottles firmly fixed in the gas bottle compartment so that they are unable to turn	
35	Protective cap set on top of the gas bottle	
36	Regulator tap on the gas bottle and gas isolator taps are closed	
37	Gas test certificate still valid (see gas inspection sticker)	
38	Gas bottles sufficiently full	

Electrical system

39	<p>Check the battery voltage of the starter battery and the living area battery. If the panel indicates that the battery voltage is too low, the respective battery has to be recharged. Observe the instructions in Chapter 9</p> <p> ▷ Commence the journey with a fully charged starter battery and living area battery.</p>	
----	--	--

4.4 Spare key



- ▷ Further information can be obtained in the separate instruction manual of the base vehicle.

The following data are required to obtain a spare key:

Spare key for	Required for obtaining	Can be obtained from
Base vehicle FIAT / CITROEN / PEUGEOT	Duplicate key Vehicle identification number	FIAT / CITROEN / PEUGEOT authorised workshop
H Line body	Vehicle identification number	Pössl/Globecar service centre

5.1 Driving the motorhome



- ▶ The base vehicle is a commercial vehicle (small truck). Adapt your manner of driving correspondingly.
- ▶ Before starting the journey and also after short breaks check whether the entrance step has been retracted completely.
- ▶ Always wear a seat belt during the journey at those seats where a seat belt is mounted.
- ▶ Never open the seat belt during the journey.
- ▶ Passengers must remain in the seats provided.
- ▶ The door lock may not be opened.
- ▶ Avoid braking suddenly.
- ▶ Only change the destination on the navigation system when the vehicle is at a standstill. Drive to a car park or stop in a safe area when changing the destination.
- ▶ Do not play a DVD on the monitor of the navigation system during the journey.



- ▷ Drive slowly on bad roads.



- ▷ If an accident occurs as a result of these instructions not being observed, the manufacturer will not be responsible for damages caused.
- ▷ The safety measures specified in Chapter 3 have to be observed.

5.2 Driving speed



- ▶ The vehicle is equipped with a powerful engine. Meaning that you have sufficient power reserves in difficult traffic situations. This high power allows a high end speed and requires above-average driving skills.
- ▶ The vehicle provides a huge surface exposed to wind. Particular danger arises when a side wind suddenly occurs.
- ▶ Uneven or one-sided loading changes the road behavior.
- ▶ On unknown roads the road surface conditions may be difficult and unexpected traffic situations may arise. Therefore adapt your driving speed to the respective traffic situation and the ambient situation for your safety.
- ▶ Observe the statutory speed limits that apply in the respective country.



- ▷ The skylights and windows are not designed for high speeds. Excessive speeds can result in noise development that is too high.

5.3 Seat belts

The vehicle is equipped with automatic three-point safety belts at those seats in the living area for which a seat belt is stipulated by law. The corresponding national regulations apply for using a seat belt.



- ▶ Before starting the journey fasten your seat belt and keep it fastened during the journey.
- ▶ Do not damage or clamp in the belts. Have damaged seat belts replaced by an authorised specialist workshop.
- ▶ Do not change the belt attachment points, the automatic retractor and the belt locks.
- ▶ Check the screwed connections of the seat belts at intervals in order to ensure that they are firmly seated.
- ▶ Use each seat belt for **one** adult person only.
- ▶ Do not belt up objects together with persons.
- ▶ Seat belts are not sufficient for persons who are less than 150 cm tall. In this case use additional retention devices. Observe the test certificates.
- ▶ Factory-set three-point safety belts must be used when attaching child restraint systems.
- ▶ Replace (have replaced) the seat belts that were in use during an accident.
- ▶ Do not tilt the backrest of the seat too far back during the journey. Otherwise the effectiveness of the seat belt is no longer ensured.

5.3.1 Using the seat belt correctly



- ▶ Do not twist the belt. The belt must be positioned smoothly against the body.
- ▶ Before applying the seat belt, adopt the correct sitting position.

5.4 Driver's seat and front passenger's seat



- ▶ Before starting the journey, rotate the seat in the direction of travel and lock in position.
- ▶ Lock the seats in the direction of travel and do not turn them during the journey.



- ▷ The driver's and front passenger's seat are a part of the base vehicle, depending on model and vehicle equipment. In this case the adjustment of the seats is described in the operating instructions of the base vehicle.

5.5 Seating arrangement



- ▶ During the journey, persons are only to sit on the permitted seats. The authorised number of seats is stipulated in the vehicle documents.
- ▶ Sitting on the divans is forbidden during the journey.
- ▶ Wearing of seat belts is compulsory at all seats.

5.6 External doors



- ▶ Only drive with the external doors locked.



- ▷ Locking the doors can prevent them from opening of their own accord, e.g. during an accident.
- ▷ Locked doors also prevent forced entry, e.g. when waiting at a set of traffic lights. However, in an emergency, locked doors make it more difficult for helpers to enter the vehicle.
- ▷ When leaving the vehicle, always lock the doors.
- ▷ The doors are part of the base vehicle. The opening and closing of the doors is described in the instruction manual of the base vehicle.

5.7 Filling up with diesel



- ▶ No appliance (e.g. heating or refrigerator) that is operated through the built-in burner may be operational while fuel is being filled up, on ferries or in the garage. Danger of explosion!

Refer to the instruction manual for the base vehicle for the position of the fuel filler neck.

6.1 Handbrake

Firmly apply the handbrake when parking the vehicle.



- ▷ An applied handbrake can prevent the driver's seat from turning. If necessary release the handbrake briefly.

6.2 Entrance step

In order to exit the vehicle, first fully extend the entrance step.

6.3 230 V connection

The vehicle can be connected to a 230 V power supply (see Chapter 9).

6.4 Refrigerator

6.4.1 Compressor refrigerator

The refrigerator only functions in 12 V operation.

7.1 External flaps



▷ Before commencing the journey, close all external flaps and lock them.



▷ When leaving the vehicle, close all external flaps.

The external flaps fitted to the vehicle are all fitted with identical locking cylinders. Therefore, all locks can be opened with a single key.

7.1.1 Flap for 230 V connection, square

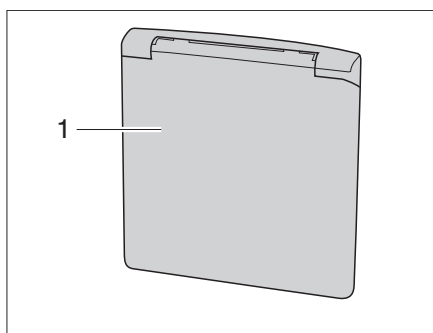

Fig. 4 Flap for 230 V connection

Opening: ■ Grip the external flap (Fig. 4,1) at the bottom and lift it upwards.

Closing: ■ Lower the external flap downward and press it shut.

7.1.2 Cap for the fresh water filler neck

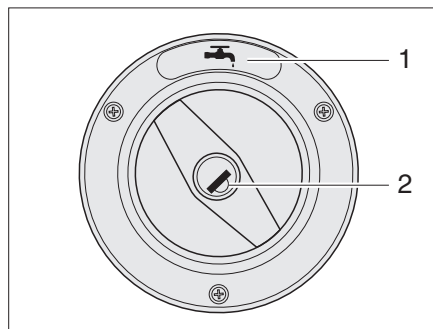

Fig. 5 Cap for the fresh water filler neck (Variant 1)

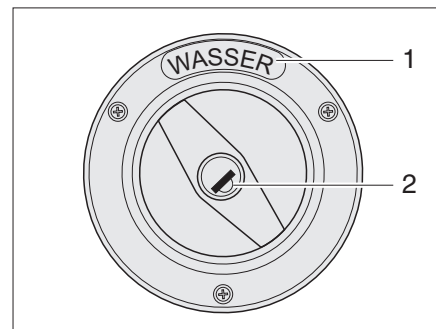

Fig. 6 Cap for the fresh water filler neck (Variant 2)



- ▷ The fresh water filler neck is identified by the symbol "☰" (Fig. 5,1) or the word "WASSER" ("WATER") (Fig. 6,1).

Opening:

- Insert the key in the locking cylinder (Fig. 5,2 or Fig. 6,2) and turn it in an anticlockwise direction.
- Remove the cap.

Closing:

- Insert the cap in the fresh water filler neck.
- Turn key clockwise.
- Remove the key.

7.2 Ventilation



- ▶ The oxygen in the vehicle interior is used up by breathing and the use of gas operated appliances. That is why the oxygen needs to be replaced on a constant basis. For this purpose, forced ventilation options (e.g. skylights with forced ventilation, mushroom-shaped vents or floor vents) are fitted to the vehicle. Never cover or block forced ventilations from inside or outside with objects as e.g. a winter mat. Keep forced ventilations clear of snow and leaves. There is a danger of suffocation due to increased CO₂ levels.



- ▷ Although sufficient ventilation is provided, in certain weather conditions, condensation can form on metal objects (e.g. screwed connections in the floor).
- ▷ Additional cold spots can occur at thermal "bridges" (e.g. mushroom-shaped vents, skylight edges, sockets, filler necks, flaps, etc.).

Condensation

Ensure that there is a continuous exchange of air by providing frequent and efficient ventilation. This is the only method for ensuring that condensation is not formed during cool weather. During the colder season, a pleasant living climate is created if heating output, air distribution and ventilation are synchronised. To avoid draft close the air outlet nozzles on the dashboard and set the air distribution of the base vehicle to air circulation. If the vehicle is laid up for a longer period, occasionally ventilate it well, especially in summer as heat accumulation can occur.

7.3 Windows



- ▷ The windows are partially fitted with a blind and a roller insect screen.
- ▷ If the blind is completely closed, exposure to direct sunlight can cause heat to accumulate between the blind and the glass window. The window could be damaged. For that reason, close the blind only 2/3 of the way in direct sunlight.
- ▷ Before commencing the journey, close the windows.
- ▷ Close and lock the hinged windows at the sliding door and behind the sliding door before using the sliding door.
- ▷ Open the blinds at the hinged window at the sliding door before using the sliding door.
- ▷ Depending on the weather, close the windows far enough to prevent moisture from entering.
- ▷ To open and close the hinged windows, open or close all catch levers which are fitted to the hinged window.



- ▷ When leaving the vehicle, always close the windows.
- ▷ In case of strong temperature differences or in extreme weather conditions, light condensation can form on the double-glazed acrylic glass. The glass is designed in such a way that condensation can evaporate when the external temperature increases. There is no danger of the double-glazed acrylic glass being damaged by condensation.
- ▷ Set all the catch levers mounted on the hinged window to the same position. This avoids tension in the window.

7.3.1 Windows living area

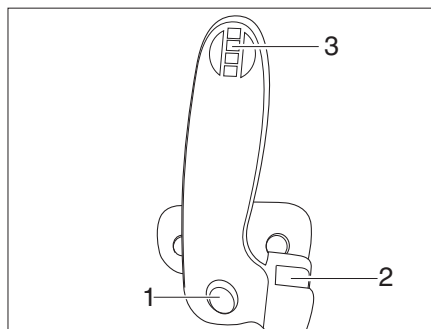

Fig. 7 Window and blind

- 1 Securing knob
- 2 Closing yoke
- 3 Catch lever

- Opening:*
- Press in the respective securing knob of the catch lever and turn the latch by 90°.
 - Open the window to the desired position. Ensure that the window does not tilt and that both hinges – on the left and right at the window – latch in parallel.

The hinged window remains locked in the required position.

- Closing:*
- Swing open the pane carefully past 90° (horizontal) and move downwards slowly.
 - Pull the window slightly inwards, press the securing knob and swivel the closing yoke into the holder
 - Do not use any force when closing, because the hinges can otherwise be damaged. At tightly closed windows the closing yoke of the latch lies within the window frame.

Continuous ventilation The window can also be set to "Continuous ventilation". One closing device of the closing yoke is fixated within the frame, the second one outside the frame. In this position the window cannot be opened from the outside.

7.3.2 Hinged window with automatic hinges



- ▷ Open the window completely in order to unblock the locking device. If the locking device is not unblocked and the window is closed nevertheless, there is the danger of the window being torn due to the massive counter-pressure.
- ▷ When opening the hinged windows, ensure that there are no torsional forces. Open and close the hinged windows evenly.
- ▷ When the rear windows are opened, do not swivel the rear door by 180°; in order to avoid a collision of the windows with the vehicle.

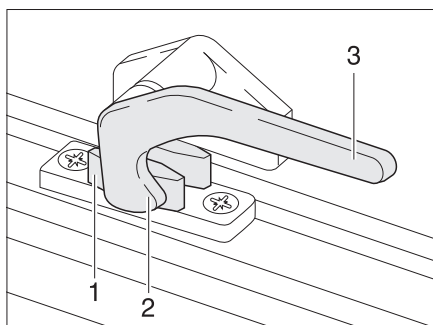

Fig. 8 Catch lever in "closed" position

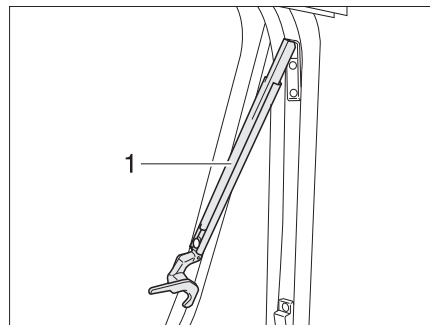

Fig. 9 Hinged window with automatic hinges, open

- Opening:**
- Turn the catch lever (Fig. 8,3) a quarter turn towards the centre of the window.
 - Open the hinged window to the desired latched position. The automatic hinge (Fig. 9,1) locks in place automatically.

The hinged window remains locked in the required position.

- Closing:**
- Open the hinged window as wide as necessary until the latch releases.
 - Close the hinged window.
 - Turn the catch lever (Fig. 8,3) a quarter turn towards the window frame. The locking catch (Fig. 8,2) is located on the inside of the window catch (Fig. 8,1).

Continuous ventilation

With the catch lever, the hinged window can be placed in two positions:

- In "Continuous ventilation" position
- In "Firmly closed" position

To place the hinged window into the "continuous ventilation" position:

- Turn the catch lever (Fig. 8,3) a quarter turn towards the centre of the window.
- Lightly open the hinged window outwards.
- Return the catch lever to its initial position. The locking catch (Fig. 8,2) has to be moved into the recess of window catch (Fig. 8,1).

During the journey, the hinged window may not be in the "continuous ventilation" position.

If it rains, the "continuous ventilation" hinged window position could lead to splashing water penetrating the living area. Therefore, close the hinged windows completely.

7.3.3 Hinged window with damping



- ▷ When opening the hinged windows, ensure that there are no torsional forces. Open and close the hinged windows evenly.

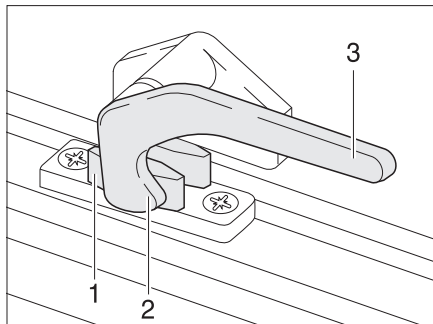

Fig. 10 Catch lever in "closed" position

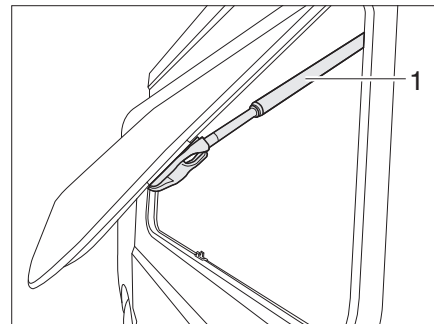

Fig. 11 Hinged window with damping, opened

- Opening:*
- Turn the catch lever (Fig. 10,3) a quarter turn towards the centre of the window.
 - Open the hinged window to the desired position.

The damping (Fig. 11,1) holds the hinged window in the desired position.

- Closing:*
- Press the hinged window into the closed position.
 - Turn the catch lever (Fig. 10,3) a quarter turn towards the window frame. The locking catch (Fig. 10,2) is located on the inside of the window catch (Fig. 10,1).

Continuous ventilation See Chapter 7.3.1.

7.3.4 Blind and roller insect screen

The windows are fitted with a blind and a roller insect screen. The blind and insect screen can be adjusted separately.

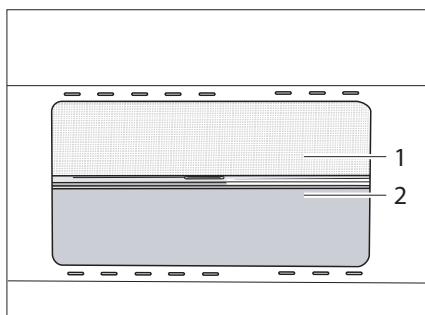

Fig. 12 Hinged window

Blind

Closing: ■ Grip into the notch (Fig. 12,2) and pull the blind from the top downwards as far as wished.

Opening: ■ Grip into the notch (Fig. 12,2) and push the blind upwards.

Roller insect screen

Closing: ■ Use the handle (Fig. 12,1) to pull the roller insect screen downwards.

Opening: ■ Use the handle (Fig. 12,1) to push the roller insect screen upwards.

7.3.5 Roman shades for driver's window and front passenger's window

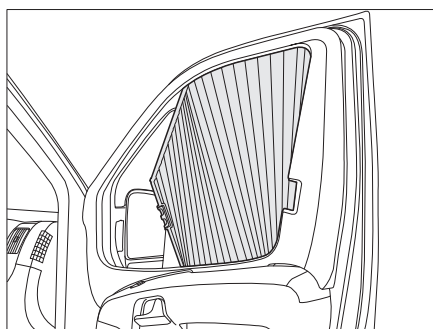

Fig. 13 Roman shades on driver's/ front passenger's windows

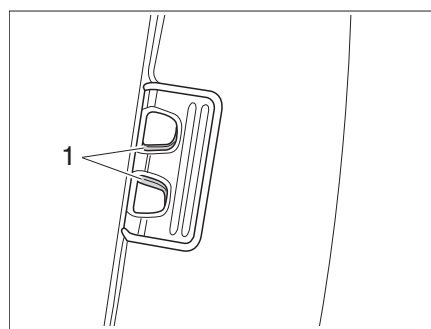

Fig. 14 Roman shade, locking mechanism

Closing: ■ Press the locking mechanism (Fig. 14,1) together and lift it slightly.
 ■ Close the Roman shades for the driver's window and the front passenger's window.

Opening: ■ Open the Roman shade for the driver's window and the front passenger's window and slide the locking mechanism into the notch.

7.3.6 Roman shade windscreen

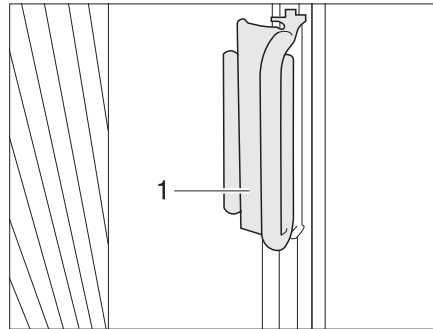

Fig. 15 Handle Roman shade for wind-screen

- Closing:*
- Grip the Roman shades at both sides of the windscreen at the handle (Fig. 15,1) and pull carefully towards the middle of the windscreen until the magnetic catch keeps the Roman shade closed.
- Opening:*
- Push the Roman shades carefully at the handle under the cover at the A-columns.
 - Push the handle (Fig. 15,1) onto the attachment. The Roman shade is secured.

7.4 Sliding door



- ▶ Ensure when closing the sliding door that no fingers or other body parts are clamped in.
Ensure that there are no persons (adults and children) in the working range when the door is closed or opened.
- ▶ Ensure that children do not use the sliding door without supervision.
- ▶ The electric sliding door opens to the rear. While the sliding door is being opened there is a risk of injury for the persons standing behind it. Open the sliding door only if the traffic situation allows it.
- ▶ Always operate the electrical sliding door with care.



- ▶ Open or close the electrical sliding door only when the vehicle is stationary.
- ▶ The sliding door must always be closed while travelling.
- ▶ In the closed position the closed sliding door must always be flush with the adjacent bodywork parts. Only then is the door closed securely and completely.



- ▷ Do not use the bottom guide of the sliding door (track roller) as an entrance step. You could injure yourself and damage the mechanism of the sliding door.

7.4.1 Sliding door, electric

The sliding door of the motorhome is opened and closed electrically. The door lock can be operated from the outside and inside.



- ▷ In order to avoid bruising caused by the electric sliding door, the closing edge has a contact strip (Fig. 16, 1). When contact is made, the movement of the sliding door is stopped immediately.

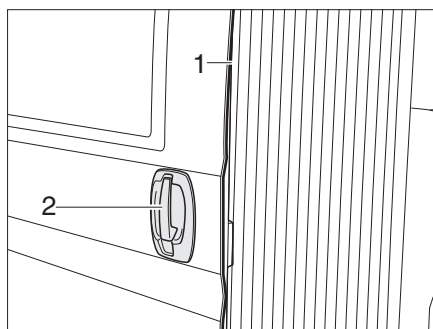

Fig. 16 Sliding door, electric - door handle on outside

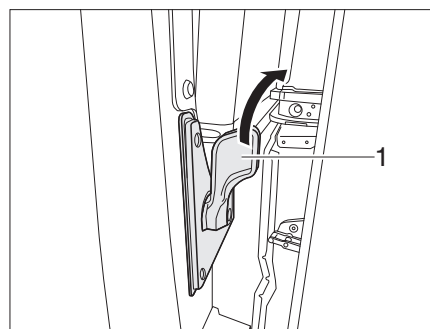

Fig. 17 Sliding door, electric - latch on inside

Sliding door outside The door lock of the sliding door is connected with the central locking system.

Opening: ■ Pull the door handle (Fig. 16,2). The electric sliding door opens completely.

Closing: ■ Pull the door handle (Fig. 16,2). The electric sliding door closes and latches into the door lock.

Sliding door inside

Opening: ■ Press the latch (Fig. 17,1) to the right. The electric sliding door opens completely.

Closing: ■ Press the latch (Fig. 17,1) to the right. The electric sliding door closes and latches into the door lock.

7.4.2 Obstacle detection function



- ▶ Ensure that no parts of the body are within the closing area of the door.
- ▶ If anyone is clamped in, immediately open the sliding door by using the door handle or the emergency unlocking mechanism.
- ▶ The obstacle detection function is solely an aid and does not replace caution when opening and closing the electrical sliding door.

The obstacle detection function can reduce the danger of crushing and squeezing injuries when opening and closing the electrical sliding door. When a larger object obstructs or impedes the sliding door during opening or closing, the door is reversed for a few centimetres in the opposite direction and then stopped. In addition warning tones are emitted.

Warning tones:

- Contact at pressure strip while closing: 1 x long
- Fault at pressure strip: 2 x long
- Overcurrent: 1 x short, 1 x long
- Blockage: 1 x short
- Undervoltage: 2 x short
- Low temperature: 3 x short
- Play protection: 4 x short
- During the closing process warning tones are emitted during the last 20 - 30 cm.

7.4.3 Emergency unlocking mechanism of the electrical sliding door

If the electrical drive of the sliding door does not function for any reason (battery depleted, drive defective, etc.), the sliding door can be disconnected from the electrical drive by using the emergency unlocking mechanism. The sliding door can then be opened and closed without electrical support. The emergency unlocking mechanism is located at the lower rail of the sliding door.



- ▶ Please note that in emergency unlocking mode the sliding door does not have an end stop that stops the door automatically. The pillar or the opened windows can be damaged during manual opening of the sliding door.
- ▶ Ensure that at emergency unlocking the lever always latches directly into the holding pin. Otherwise damage to the vehicle would arise through the carrier arm swivelled downwards.

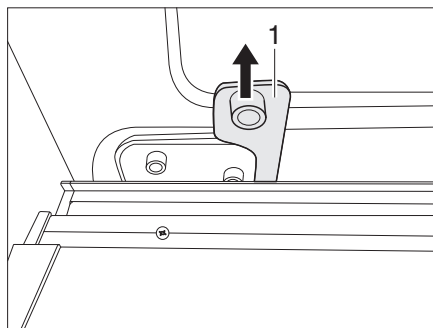

Fig. 18 Emergency unlocking mechanism

- Pull the emergency unlocking mechanism (Fig. 18,1) forcefully upwards and latch it into the holding pin. The sliding door is now disconnected and can only be opened and closed manually.
 - Always open the sliding door completely or, respectively, until the mechanical stop has been reached. Only in this position is the door kept open through a retainer. When closing the door it has to be pulled with force out of the retainer.
- ▷ The emergency unlocking mechanism can only be deactivated again by the customer service.



7.4.4 Power closing aid

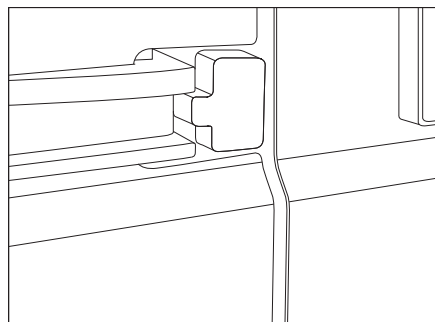

Fig. 19 Power closing aid (external)

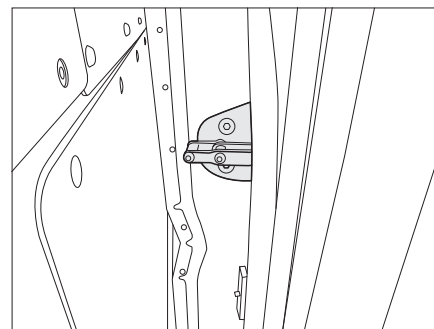

Fig. 20 Power closing aid - closing bar on inside

The vehicle is equipped with an electro-mechanical power closing aid for the sliding door. The sliding door can be closed with only a little effort thanks to the power closing aid.

- Closing:*
- Slide the sliding door with slow sliding speed and little effort into the end position and press.

From this position the power closing aid automatically moves the sliding door into the closing position.



If the sliding door still projects clearly over the vehicle side, the sliding door was not pressed sufficiently strongly into the end position.

- ▷ Close the sliding door once more.

- Opening:*
- Open the sliding door as usual using the inner or outer door handle of the vehicle.

The power closing aid is without function when the sliding door is opened.



- ▷ The power closing aid can be dismantled if it fails. The standard closing bar is installed in the vehicle instead of the power closing aid. The standard closing bar forms part of the emergency set which is located in the glove compartment of the vehicle.

Particular points

The following particular points have to be observed when using the sliding door.

Particular point	Remedy
Rapid opening and renewed closing of the door	If the door is opened and is to be closed immediately again, a waiting period of 3 seconds has to be observed.
Locking the vehicle with a central locking system	Wait until the locking cycle of the power closing aid is complete and then close the vehicle using the central locking system.
Weak battery	The power closing aid switches off when the battery is weak. However, the door can still be opened and closed manually. When the battery becomes weaker the closing process takes a bit longer.
Disconnect the battery or use the cut-off switch of the living area battery	Disconnect the battery only if the sliding door is closed correctly.
Operation at low temperatures	The power closing aid is switched off for safety reasons at external temperatures of approx. -20 to -25 °C.

7.4.5 Insect screen at the sliding door



- ▷ Open the insect screen completely before the conversion door is closed.
- ▷ The insect screen needs to be serviced on a regular basis according to the manufacturer's guidelines. This includes regularly cleaning the rails and readjusting the line tension. Please pay attention to the guidelines issued by the manufacturer.

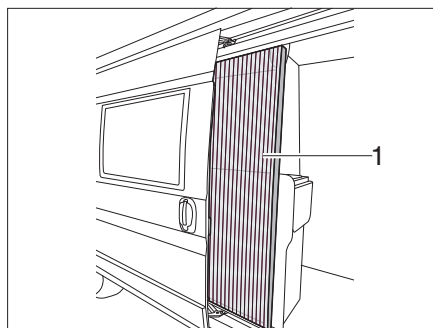

Fig. 21 Insect screen

- Closing:* ■ Pull out the insect screen completely at the strip (Fig. 21,1).
- Opening:* ■ Push the insect screen back into the starting position at the strip (Fig. 21,1).

7.5 Skylights and SkyRoof®



- ▶ The apertures for forced ventilation must always be kept open.
- ▶ Never cover or block forced ventilations with objects such as e.g. a winter mat.
- ▶ Keep forced ventilations clear of snow and leaves.



- ▷ The skylights and the SkyRoof® are fitted with a blind or Roman shade and with a roller insect screen or folding insect screen. The Roman shade and folding insect screen are made of thin woven fabric. In order not to damage the Roman shade or the insect screen, grasp the respective handle and carefully return it to the initial position.
- ▷ If the blind or the Roman shade is completely closed, exposure to direct sunlight can cause heat to accumulate between the blind/the Roman shade and the skylight. The skylight could be damaged. For that reason, close the blind/Roman shade only 2/3 of the way in direct sunlight. Open the skylight slightly or move it to ventilation position.
- ▷ Depending on the weather, close the skylights far enough to prevent moisture from entering.
- ▷ Never step on the skylights.
- ▷ Before commencing the journey, close the skylights.
- ▷ Before commencing the journey, check that the skylights are closed and locked.
- ▷ Before commencing the journey, open the Roman shades.
- ▷ Relieve the seal for extended periods of parking (see section 12.1.8).



- ▷ When leaving the vehicle, always close the skylights.

7.5.1 Hinged skylight



- ▷ If it rains, the ventilation skylight position could lead to water entering the living area. Therefore close hinged skylight completely.

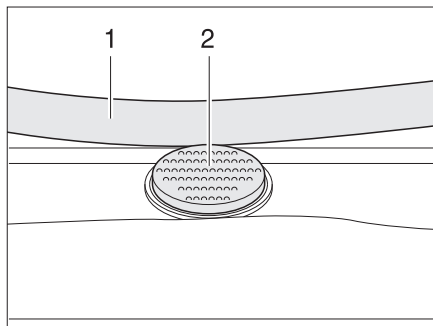

Fig. 22 Securing knob at the hinged skylight

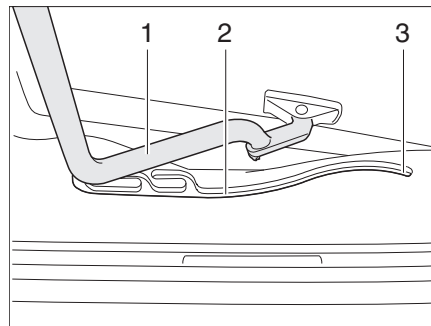

Fig. 23 Hinged skylight, guide

The hinged skylight is opened on one side only.

- Opening:**
- Press the safety knob (Fig. 22,2) and pull the bar (Fig. 22,1) down with both hands.
 - Pull the bar (Fig. 23,1) in the guides (Fig. 23,2) to the rearmost position (Fig. 23,3).
- Closing:**
- Use both hands to push the bar (Fig. 23,1) slightly upwards.
 - Push the bar back in the guides.
 - Push the bar upwards with both hands until it is above the safety knob (Fig. 22,2).

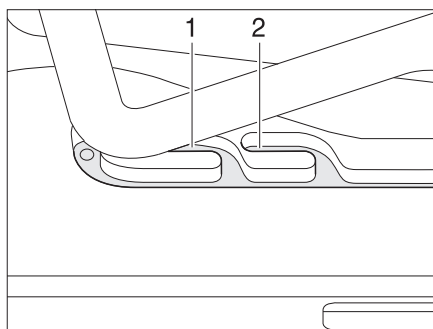

Fig. 24 Hinged skylight in ventilation position

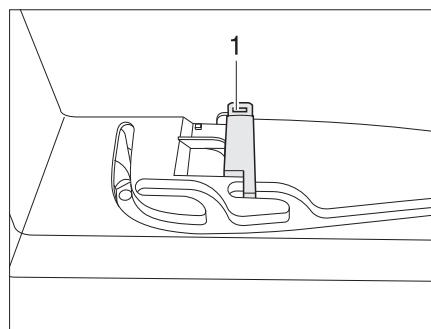

Fig. 25 Locking mechanism in ventilation position

Ventilation position

The hinged skylight can be put in two ventilation positions: Bad weather position (Fig. 24,1) and central position (Fig. 24,2). Depending on the model, the skylight can be locked in the central position with the latch (Fig. 25,1).

- Press the safety knob (Fig. 22,2) and pull the bar (Fig. 22,1) down with both hands.
- Pull the bar in the guides (Fig. 23,2) to the desired position.
- Push the bar slightly upwards and into the selected guide (Fig. 24,1 or 2) and lock if necessary.

Roman shade

To close and open the Roman shade:

Closing: ■ Pull out Roman shade at the handle and release in the required position. The Roman shade will stay in that position.

Opening: ■ Slowly push the Roman shade at the handle to its initial position.

Insect screen To close and open the insect screen:

Closing: ■ Pull the insect screen by the handle to the opposite handle of the Roman shade.

Opening: ■ Use handle to return the insect screen slowly to its initial position.

7.6 Wind-up skylight and SkyRoof®

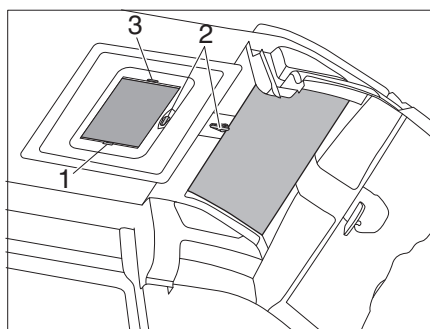

Fig. 26 Wind-up skylight with SkyRoof®

The wind-up skylight and the SkyRoof® can be opened using the manual crank.

Opening: ■ Rotate the hand crank (Fig. 26,2) counterclockwise until a resistance can be felt (max. opening angle 60°, only for Heki).

Closing: ■ Rotate the hand crank clockwise until the wind-up skylight is closed. The wind-up skylight can be locked after rotating two or three more times.
 ■ Check the locking mechanism. To do so, press your hand against the acrylic glass.

Roman shade The Roman shade can be closed in any position, as desired.

Closing: ■ Pull the handle of the Roman shade (Fig. 26,3) and release in the desired position. The Roman shade will stay in that position.

Opening: ■ Slowly push the Roman shade at the handle (Fig. 26,3) to its initial position.

Insect screen

Closing: ■ Pull the insect screen by the handle (Fig. 26,1) to the opposite handle of the Roman shade (Fig. 26,3).

Opening: ■ Push insect screen at the handle to its initial position.

7.7 Multiroof (optional)

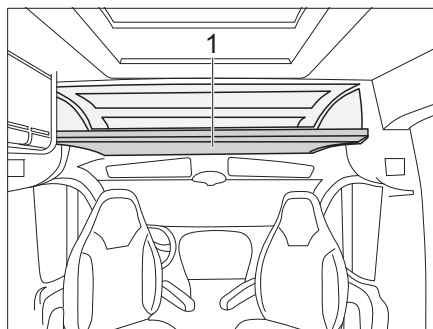

Fig. 27 Multiroof (optional)

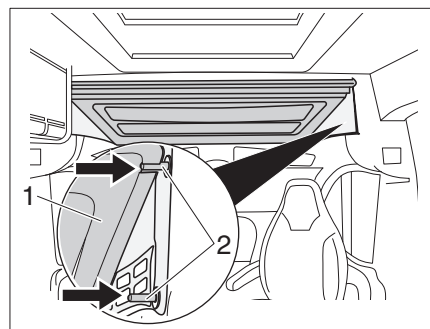

Fig. 28 Multiroof folded upwards

Additional storage space can be created with the foldable Multiroof (Fig. 27,1).



- ▷ Before conversion, check that there are no heavy objects in the tray.
- ▷ When folding down the Multiroof (Fig. 28,1), make sure that it always rests securely on both locking pins (Fig. 28,2) on the left and right.

The Multiroof (Fig. 28,1) can be positioned at two different heights with the locking pins (Fig. 28,2).

Fold Multiroof upward or downward:

- Lift the Multiroof (Fig. 28,1) using one hand. Press on the upper or lower locking pins (Fig. 28,2) with the other hand and clip the Multiroof into the desired position.

Removing/installing the Multiroof



The Multiroof can be completely removed from the vehicle.

- ▷ Carry out the removal with the help of a second person.

Removing:

- Gently push the Multiroof (Fig. 28,1) upwards to remove it from the locking pins (Fig. 28,2).
- Remove the Multiroof carefully.

Installing:



- The installation is done in reverse order to the removal.
- ▷ When installing the Multiroof, take care to ensure it engages and latches into the locking bolts.
- ▷ Before driving, check the Multiroof is locked in place and cannot move.
- ▷ The maximum permissible load for the Multiroof is 7 kg.
- ▷ When driving, secure the load from falling.
- ▷ Clip the safety net holder into the slots provided.

7.8 Locking mechanism of the cupboard doors

- Opening doors:*
- Press in the push button and let it spring out.
 - Pull open the door.

- Closing doors:*
- Close the door.
 - Press in the push button to lock.

7.9 Table

7.9.1 Swivel table (optional)

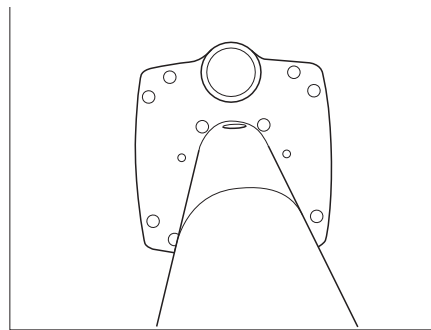

Fig. 29 Unlocking of table lower section (similar to illustration)

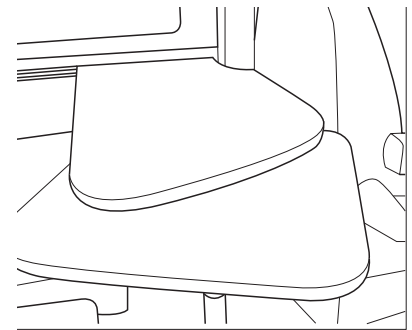

Fig. 30 Table lower section folded out (similar to illustration)

- Folding out table:*
- Pull the securing knob on the bottom of the table downwards.
 - At the same time turn the lower table-top and bring it into the desired position.

7.9.2 Suspension table with tray (optional)

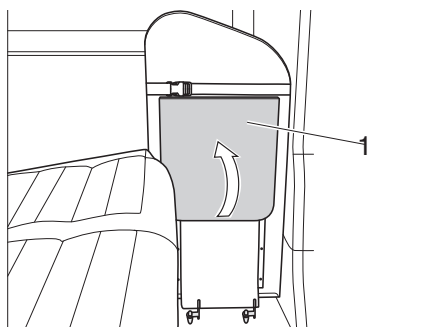

Fig. 31 Folding out the tray

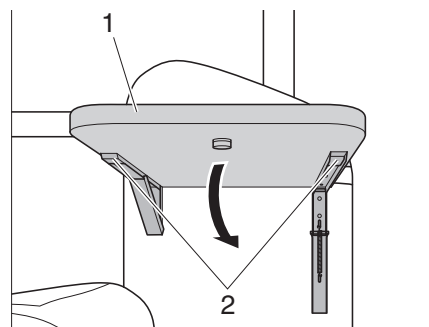

Fig. 32 Folding in the tray

Folding out the tray: ■ Swivel the tray (Fig. 31,1) upwards until the holder locks into place.

Folding in the tray: ■ Press the two release levers (Fig. 32,2) under the tray and swing the tray (Fig. 32,1) down.

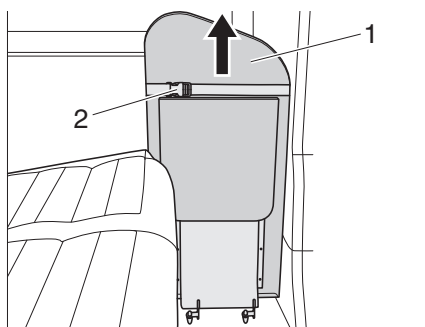

Fig. 33 Folding out the table-top

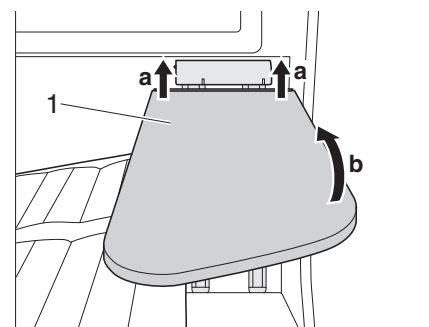

Fig. 34 Folding in the table-top

Folding out the table-top: ■ Open the fastener of the tensioning strap (Fig. 33,2).
 ■ Push the table-top (Fig. 33,1) upwards as far as it will go and then swivel it downwards until the holder engages.

Folding in the table-top: ■ Lift the table top (Fig. 34,1) (a) and fold it up (b).
 ■ Push down the table-top (Fig. 34,1).
 ■ Close the fastener of the tensioning strap (Fig. 33,2).

7.10 Sockets living area



- ▶ The maximum load of the 12-Volt sockets lies at 120 Watt.

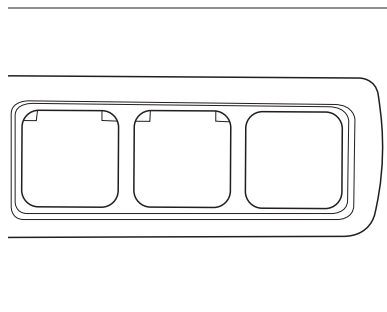

Fig. 35 Sockets living area

All the models are equipped with a 230 Volt socket. When the vehicle is connected with the 230-Volt mains through the external power supply, 230 Volt alternating current is available.

All the models are equipped with a 12 Volt socket. Further 12 Volt appliances can be connected to the socket in the bathroom.

7.11 Lamps



- ▶ Lamps and light fittings can develop heat.
- ▶ Let the lamps and light fittings cool down before touching them.
- ▶ When the light is switched on or is still hot, a safety distance of at least 30 cm to combustible material such as net curtains or curtains has to be maintained. Fire hazard!

The motorhome is equipped with different light sources. All the lamps only function if the main switch at the control panel is switched on. The entry lighting behind the front passenger's seat and the floor lighting function independently of the control panel.

The body lighting in the sleeping area as well as in the living area (above the table) have an additional on-off switch at the skirting board.

The lamps of the LED lamps cannot be replaced. In the case of a fault the entire lamp has to be replaced by qualified personnel.

7.12 Beds

7.12.1 Bed in the pop-up roof



- ▶ The maximum load for the bed in the pop-up roof amounts to 200 kg.
- ▶ Fold in the pop-up roof before commencing the journey.
- ▶ Only use the bed in the pop-up roof if the safety guards are in position.
- ▶ Never leave small children without supervision.
- ▶ Ensure in particular with regard to small children less than 6 years of age, that they cannot fall out of the bed.
- ▶ Switch off the reading lamps in the pop-up roof when it is folded in. Fire hazard!



- ▷ Mount the safety guard when the persons are already in the pop-up roof.

Opening the pop-up roof

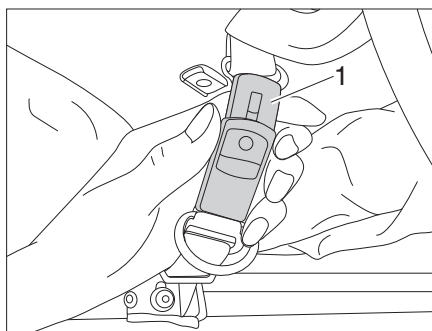

Fig. 36 Open the securing belt

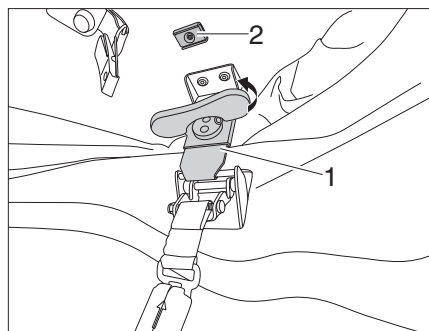

Fig. 37 Releasing the locking mechanisms

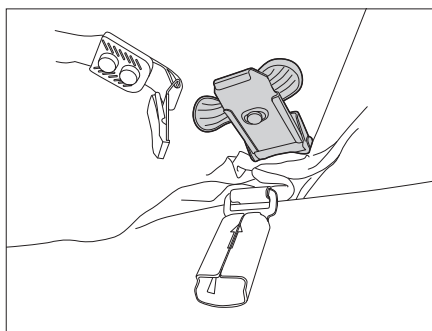

Fig. 38 Fastening the locking mechanism

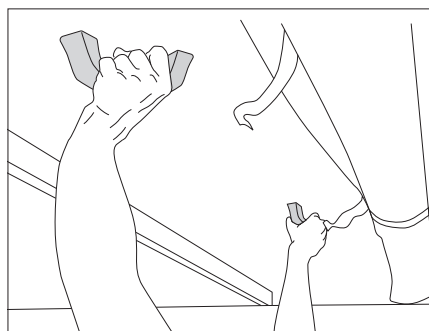

Fig. 39 Pushing up the pop-up roof

- Open the securing belts (Fig. 36,1).
- Set up the twist grips of the left- and right-hand locking mechanism (Fig. 37,1) and turn counter-clockwise until the locking mechanisms are loosened.
- Fold the twist grip further downward and attach the locking mechanism to the magnet (Fig. 37,2) (Fig. 38).
- Hold the grips with both hands and push the pop-up roof upwards (Fig. 39).

Access ladder

Always use the access ladder provided as standard to access the overcab bed.



- ▷ The access ladder is not intended to be leaned on, but may only be used when suspended.
- ▷ Observe the other safety instructions in the accompanying manufacturer's instruction manual.

Attaching:

- Hook the access ladder onto the pop-up roof with the two brackets.

Closing the pop-up roof

- ▷ Before closing the pop-up roof open at least one door of the vehicle. Material damage may otherwise occur through excess pressure.
- ▷ When closing the pop-up roof ensure that the cloth bellows are not clamped in.
- ▷ Ensure that the locking levers (Fig. 40,1) are attached to the magnet at the top.

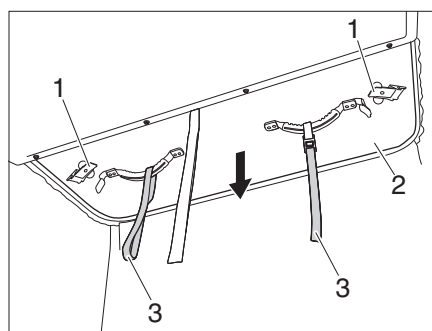

Fig. 40 Pulling the pop-up roof downwards

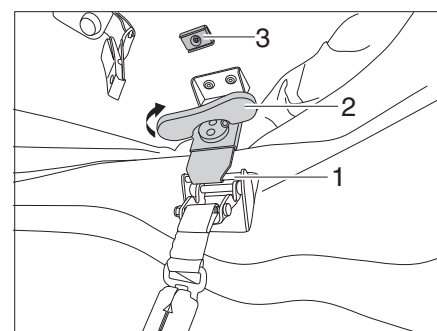

Fig. 41 Tensioning the locking mechanism

- Open a door at the vehicle.
- Check whether the locking mechanism are secured by the magnets (Fig. 41,3).
- Use the pulling devices (Fig. 40,3) to pull the pop-up roof (Fig. 40,2) downwards.
- Loosen the locking lever (Fig. 40,1) from the magnet (Fig. 41,3) and attach it into the catch (Fig. 41,1).
- Turn the twist grip (Fig. 41,2) of the locking mechanism clockwise until the locking mechanism is fastened.
- Fold the twist grip (Fig. 41,2) upwards.
- Close the securing belts (Fig. 36,1).

7.13 Additional seat

The rear two-seater bench seat in the vehicle can be converted into a three-seater bench seat. The third seat is under the lid of the chest.



- ▶ Make sure the extra seat does not block the emergency exit. If there are people in the rear of the vehicle, the seat must not be set up as the emergency exit is blocked by the sliding door.



- ▷ The conversion from a single seat to a two-seater bench is done in the same way.

7.13.1 Set up additional seating

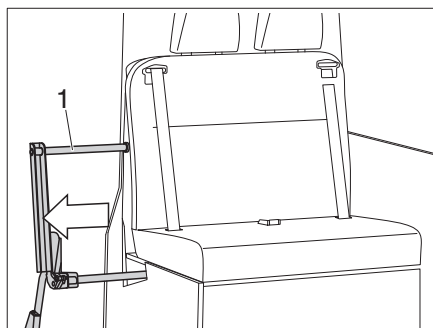

Fig. 42 Pulling out the seat extension

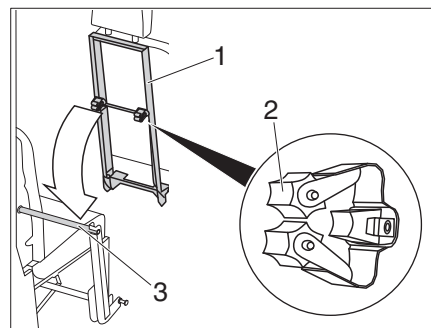

Fig. 43 Hook in backrest

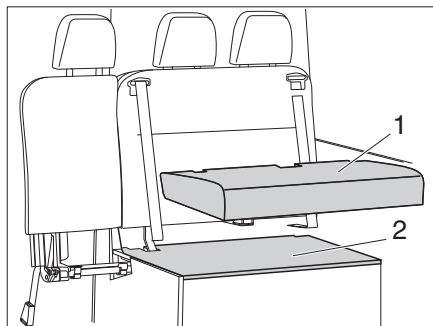

Fig. 44 Remove the seat cushion

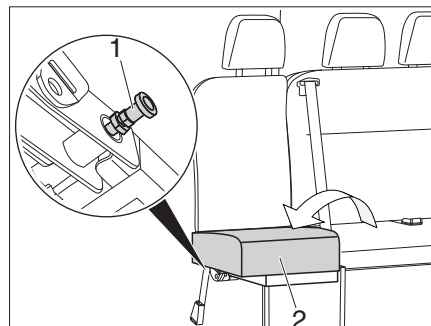

Fig. 45 Fold out seat

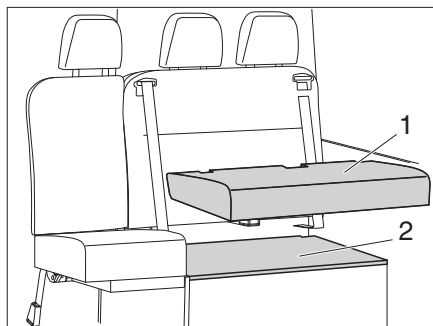

Fig. 46 Seat cushion installation

- Pull the seat extension (Fig. 42,1) out of the two-person seat.
- Hook the backrest (Fig. 43,1) with the two clips (Fig. 43,2) into the seat widening (Fig. 42,3).

- Remove the seat cushion (Fig. 44,1) and the chest cover (Fig. 42,2).
- Fold out the seat (Fig. 45,2) and secure it with the lock (Fig. 45,1).
- Insert the chest cover (Fig. 46,2) and place the seat cushion (Fig. 46,1).

7.13.2 Stow additional seat

The additional seat is stowed in reverse order for setting up.



- ▷ For the version including a single seat plus an additional seat, the cushion must be removed and stowed safely before folding in the seat extension.

8.1 General



- ▶ Close all gas isolator taps and the regulator tap before commencing the journey and when leaving the vehicle.
- ▶ Closing of the isolator and regulator valves is not required at vehicles that are equipped with a crash sensor.
- ▶ No appliance (e.g. heating or refrigerator) that is operated through the built-in burner may be operational while fuel is being filled up, on ferries or in the garage. Danger of explosion!
- ▶ If an appliance is operated through a burner, do not start the appliance up in closed areas (e.g. garages). Danger of poisoning and suffocation!
- ▶ Have the gas system serviced, repaired or altered by an authorised workshop only.
- ▶ Have the gas system checked by an authorised specialist workshop before starting up and according to the national regulations. This also applies for not registered vehicles. For modifications to the gas system have the gas system immediately checked by an authorised specialist workshop.
- ▶ The gas pressure regulator and the exhaust gas pipes also have to be checked. The gas pressure regulator has to be replaced at least every 10 years. The vehicle owner is responsible for seeing that this is carried out.
- ▶ The gas filter cartridge has to be replaced every 2 years.
- ▶ In case of a defect of the gas system (gas odour, high gas consumption) there is danger of explosion! Close the regulator tap on the gas bottle immediately. Open doors and windows and ventilate well.
- ▶ In case of a defect in the gas system: Do not smoke; do not ignite any open flames, and do not operate electric switches (light switches etc.).
- ▶ Have the defect in the gas system repaired by an authorised specialist workshop.
- ▶ Open a skylight or a window before taking open sources of combustion (gas cooker) into service.
- ▶ Do not use the gas cooker or gas oven for heating purposes.
- ▶ If the vehicle or gas devices are not used, close the regulator tap on the gas bottle.
- ▶ If there are several gas devices, each gas device must have its own gas isolator tap. If individual gas devices are not in use, close the respective gas isolator tap.
- ▶ Ignition safety valves must close within 1 minute after the gas flame has extinguished. A clicking sound is audible. Check function from time to time.
- ▶ The installed gas appliances are designed for use solely with propane or butane gas or a mixture of both. The gas pressure regulator as well as all installed gas devices are set for a gas pressure of 30 mbar.
- ▶ Propane gas is capable of gasification up to $-42\text{ }^{\circ}\text{C}$, whereas butane gas gasifies at $0\text{ }^{\circ}\text{C}$. Below these temperatures no gas pressure is available. Butane gas is unsuitable for use in winter.



- ▶ Regularly inspect the gas tube fitted to the gas bottle connection for tightness. The gas tube must not have any tears and must not be porous. Have the gas tube replaced by an authorised specialist workshop no later than 10 years after the manufacturing date. The operator of the gas system must see to it that the parts are replaced.
- ▶ Due to its function and construction, the gas bottle compartment is a space which is open to the exterior. Never cover or block the standard forced ventilation. Otherwise leaking gas cannot be dispersed to the outside.
- ▶ Do not use the gas bottle compartment as storage space as it is not moisture-proof.
- ▶ Secure the gas bottle compartment in order to prevent unauthorised persons opening it. To do so lock the access.
- ▶ The regulator tap on the gas bottle must be accessible.
- ▶ Only connect gas-operated devices (e.g. gas grill) which have been designed for a gas pressure of 30 mbar.
- ▶ The exhaust gas pipe must be fitted tightly to the heating system and to the vent and must be sealed. The exhaust gas pipe must not show any evidence of damage.
- ▶ Exhaust fumes must be able to escape into the atmosphere unhindered and fresh air must be able to enter unhindered. Therefore keep the waste gas vents and intake openings clean and free (e.g. of snow and ice). No snow walls or aprons may be allowed to lie against the vehicle.
- ▶ Faults can occur when igniting gas at altitudes exceeding 1.000 m above sea level. This is not a malfunction of the appliance.

8.2 Gas bottles



- ▶ Gas bottles are only to be transported within the designated gas bottle compartment.
- ▶ Place gas bottles vertically in the gas bottle compartment.
- ▶ Tie down gas bottles so that they are unable to turn or tilt.
- ▶ If the gas bottles are not connected to the gas tube, always place the protective cap on top.
- ▶ Close the regulator tap on the gas bottle before the gas pressure regulator or gas tube are removed from the gas bottle.
- ▶ Use your hands only to connect the gas pressure regulator or the gas tube to the gas bottles. Do not use any tools.
- ▶ Only use special gas pressure regulators with a safety valve designed for vehicle use. Other gas pressure regulators are not permitted and cannot meet the demanding requirements.
- ▶ Use only 11 kg or 5 kg gas bottles. Camping gas bottles with a built-in reflux valve (blue bottle with max. 2.5 or 3 kg content) are permitted in exceptional cases with a safety valve.
- ▶ Never block the ventilation openings in the floor under the gas bottles.
- ▶ Never block the access to the gas bottles. Observe the advice sign.



- ▷ Screwed connections on the gas pressure regulator have left-handed threads.
- ▷ For gas-operated units the gas pressure must be reduced to 30 mbar.
- ▷ Connect gas pressure regulator complete with safety valve directly to bottle valve.
The gas pressure regulator reduces the gas pressure in the gas bottle down to the operating pressure of the gas devices.
- ▷ For filling and connecting the gas bottles in Europe the accessories shops have corresponding Euro filling sets and Euro bottle sets.
- ▷ Information is available at the dealers and service centres.

8.3 Changing gas bottles

The gas bottle compartment is located in the left-hand vehicle rear under the bed (Summit 600/640) or in the right-hand vehicle rear under the bed (Summit 600 plus). The gas storage space is conceived for two 11 kg gas bottles (Summit 600/640) or for one 11 kg and one 5 kg gas bottle (Summit 600 plus).



- ▶ When changing gas bottles, do not smoke or create any open fire.
- ▶ When you have changed the gas bottle, check whether gas escapes at the connection points and unions. Use a leakage search spray to spray the relevant connection point or union. These agents are available at the accessories shop.

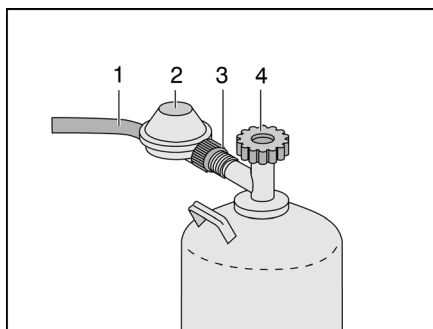
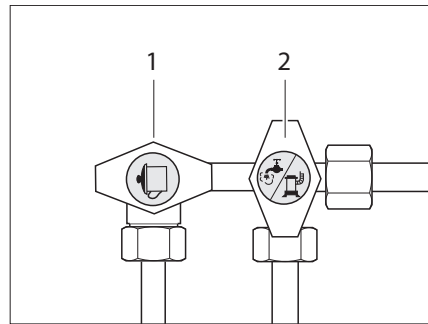

Fig. 47 Gas bottle connection

- Close the regulator tap (Fig. 47,4) on the gas bottle. Pay attention to the direction of the arrow.
- Hold the gas pressure regulator (Fig. 47,2) and open the knurled nut (Fig. 47,3) (left-handed thread).
- Remove the gas pressure regulator and the gas tube (Fig. 47,1) from the gas bottle.
- Release the fixing belts and remove the gas bottle.
- Place a filled gas bottle in the gas bottle compartment.
- Fix gas bottle in place with the fixing belts.
- Position the gas pressure regulator (Fig. 47,2) and the gas tube (Fig. 47,1) on the gas bottle and tighten the knurled nut (Fig. 47,3) by hand (left-handed thread).

8.4 Gas isolator taps



- 1 Cooker
- 2 Heater/boiler

Fig. 48 Symbols for the gas isolator taps

A gas isolator tap (Fig. 48) for every gas device is built into the vehicle. The gas isolator taps are located under the rear bed on the left-hand vehicle side.

8.5 Configuration of the gas bottle in the gas bottle compartment during driving

During driving no appliances may be connected to the gas bottle. Gas bottles in the gas compartment have to be configured as described for the journey.

Configuring gas bottles:

- Close the gas bottle isolator tap on the gas bottle.
- Dismount the pressure regulator from the gas bottle and store it securely.
- Place the protective hood onto the gas bottle (Fig. 50).

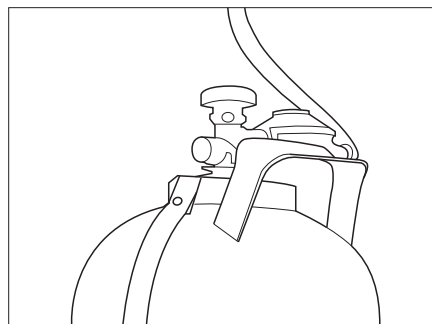

Fig. 49 Gas bottle during stationary use

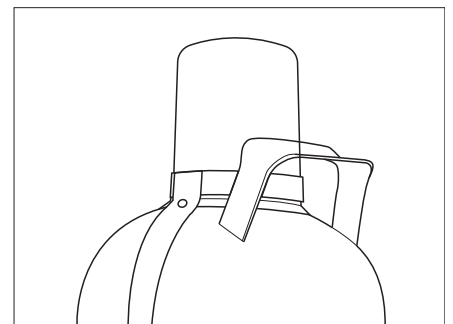

Fig. 50 Gas bottle during driving



- ▷ A two-bottle gas system "Truma-DuoControl CS" is available optionally.
- ▷ Further information is available in the respective separate instruction manuals of the manufacturer.

9.1 General safety instructions



- ▶ Only allow qualified personnel to work on the electrical system.
- ▶ Do not perform any service or repair work on the electrical box.
- ▶ If the cables or housing of the electrical box are damaged, no longer use the device and disconnect it from the mains voltage.
- ▶ Do not let any liquids enter the electrical box.
- ▶ Only use original fuses or E-T-A type 1620 circuit breakers with the specified values.
- ▶ Only replace defective fuses when the cause of the defect is known and has been remedied. Never bridge or repair a fuse.

The vehicle is a safe place during a storm (Faraday cage). However, to protect the electrical devices, disconnect the 230 V connection and retract the antennae as a precaution.

Operation with emergency generators



- Fluctuations when operating the emergency generator may damage the electronic equipment.
- ▷ Connect overvoltage protection upstream to the electrical box.
 - ▷ When using an emergency generator observe the specifications of the manufacturer.

9.2 12 V power supply



- ▷ To disconnect **all** electrical 12 V appliances from the power supply, disconnect the living area battery from the 12 V power supply. To do this, trip the main fuse.

The body's electrical system can be completely disconnected from the body battery using the battery isolator switch. This prevents the body battery from discharging quickly during long periods of inactivity without regular charging, resulting in a deep discharge of the battery.

The battery isolator switch is located on the seat console of the driver's seat.

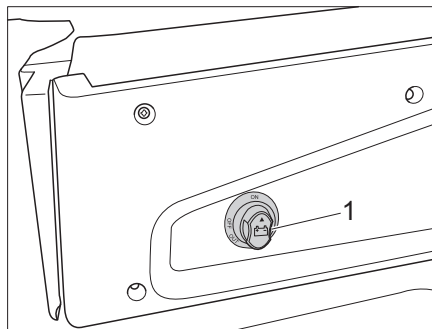

Fig. 51 Battery cut-off switch

When the vehicle is not connected to the 230 V power supply or the 230 V power supply is switched off, the living area battery supplies the living area with 12 VDC. The living area battery has a limited power supply only. For this reason, electrical appliances such as the radio and the lights should not be operated for a long time without using the 230 V power supply.

The 12 V power supply can be cut off with the 12 V main switch on the control panel. The heater and the electrical entrance step remain ready for operation. When the vehicle engine is running, the vehicle alternator recharges the living area battery and the starter battery.

Compressor refrigerator The refrigerator is only operated with 12 V.

9.2.1 Living area battery



- ▷ Prior to commencing a journey ensure the living area battery is fully charged. For this reason charge the living area battery before commencing the journey when required.
- ▷ During the trip, use every opportunity to charge the living area battery.
- ▷ After the trip and before temporarily turning off the vehicle, check the status of the living area battery and charge if necessary.
- ▷ Longer total discharge damages the battery irreparably.
- ▷ Only use the installed charging module of the electrical box to charge the living area battery.
- ▷ Irreparable damage to the living area battery will result if it is overcharged.

The charging status of the living area battery can be checked on the panel.

Location The living area battery is installed under the front passenger's seat in the seat console. This is also where the main fuse of the living area battery is found.

Changing Batteries have a limited service life and therefore need to be replaced from time to time. When changing a battery, the charging management settings for the electrical box need to be checked and changed where necessary.



- ▷ The living area battery may only be replaced by a specialist dealer.

9.3 Charging unit/booster

The electrical box with an integrated charging function and fuse protection for the 12 V consumers and 230 V power supply is located under the front flap of the driver's seat or in the cabinet area of the living area, depending on the model.



- ▷ The charging unit and booster are fixed components of the electrical box and always switched on.
- ▷ The charging unit heats up during operation. In order to avoid overheating, the battery is charged at a reduced charging current before the regular charging program starts if the battery is totally discharged.

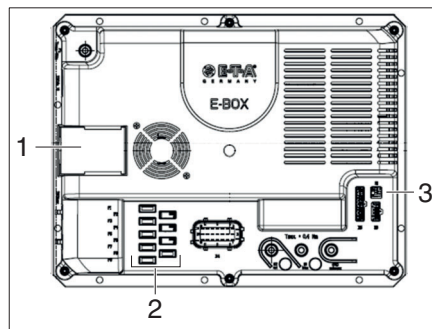

Fig. 52 230 V automatic circuit breaker and charging unit

- 1 230 V automatic circuit breaker
- 2 Fuses
- 3 DIP switch

9.3.1 Charging using a 230 V power supply

If the vehicle is connected to the 230 V power supply, the living area battery and the starter battery are automatically charged by the charger module in the electrical box. The starter battery is charged with a corresponding float charge. The charging current is adapted to suit the charging status of the living area battery.



- ▷ To make use of the maximum output from the charger module, switch off all electrical appliances during charging.

9.3.2 Charging using the vehicle engine

When the vehicle engine is running, the vehicle alternator recharges the living area battery and the starter battery. When the vehicle engine is switched off, the batteries are automatically disconnected from one another by the charging module in the electrical box. This prevents the starter battery from being run down by electrical appliances in the living area. The starting capability of the vehicle is thus preserved. The charging condition of the living area battery or the starter battery can be checked on the panel.

9.3.3 Charging management settings for battery replacements

The electrical box enables the use of lead acid batteries, AGM batteries, dryfill batteries or lithium batteries (LiFePO4). In order to prevent damage to the living area battery, the DIP switch (Fig. 53) must be configured for the type of battery installed.

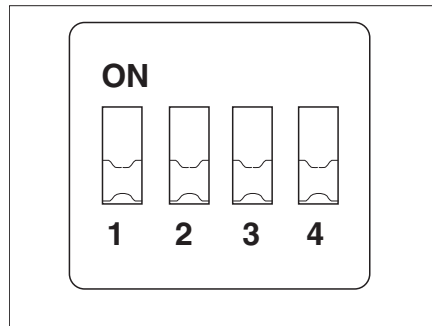

Fig. 53 DIP switch

Battery type	Switch 1	Switch 2
Lead acid battery	Off	Off
AGM battery	On	Off
Dryfill battery	Off	On
Lithium battery (LiFePO4)	On	On



- ▷ The manufacturer recommends using a temperature sensor to safely and efficiently charge the body battery. Use of a temperature sensor is mandatory for lithium batteries.

Temperature sensor	Switch 3	Switch 4
Sensor ON	Off	Off
Sensor OFF	On	On

9.4 Fuses



- ▶ Only replace defective fuses when the cause of the defect is known and has been remedied.
- ▶ Only replace defective fuses when the power supply is switched off.
- ▶ Never bridge or repair fuses.

9.4.1 12 V fuses

The appliances connected to the 12 V power supply in the living area are fused with dedicated vehicle mini fuses (11 mm).

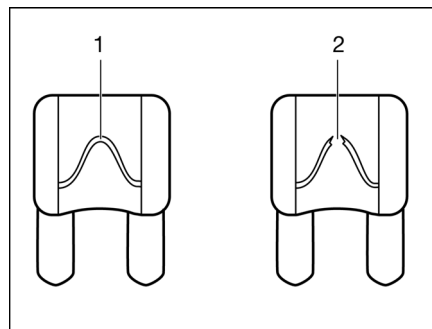

- 1 Unbroken fuse element
- 2 Broken fuse element

Fig. 54 12 V fuse

An intact 12 V fuse can be detected by the unbroken fuse element. If the fuse element is broken, the fuse needs to be replaced.

When replacing fuses, only use blade-type fuses that correspond in value and colour to the fuse to be replaced. Consult the table in chapter 9.4.2 for information on the function, values and colour.

9.4.2 12 Volt fuses for appliances

The 12 V fuses are located in the electrical box, which is either installed under the front flap of the driver's seat or at the front of the seat bench depending on the vehicle model. Solely standardised plug fuses of various fuse ratings are used.

These mini fuses are commonly used in the automotive sector. In order to replace a defective fuse it is pulled out of its holder and replaced by an identical fuse (amperage and colour). Spare fuses are commonly available, for example at fuel stations.

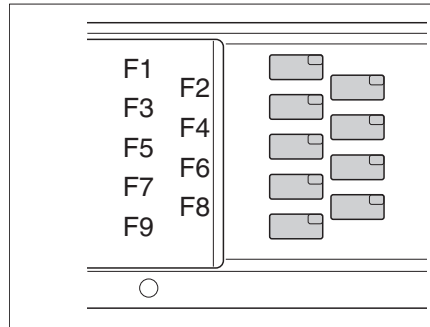

Fig. 55 12 V fuses in the electrical box



► The ratings of the fuses to be used are listed in the following table. The specified values for the fuses refer to the original equipment of the vehicle. Changes may only be carried out by qualified personnel.

Fuse No.	Rating	Colour	Appliance
F1	7.5 A	Brown	Load circuit A
F2	10 A	Red	Heater (12 V continuous voltage)
F3	10 A	Red	Water pump
F4	5 A	Light brown	Load circuit D (12 V continuous voltage)
F5	10 A	Red	Load circuit C
F6	15 A	Blue	Electrical step (12 V continuous voltage)
F7	5 A	Light brown	Load circuit B
F8	3 A	Purple	D+
F9	10 A	Red	Refrigerator

12 V main fuse for the living area battery

The main fuse (Fig. 56,1) is fitted next to the living area battery.

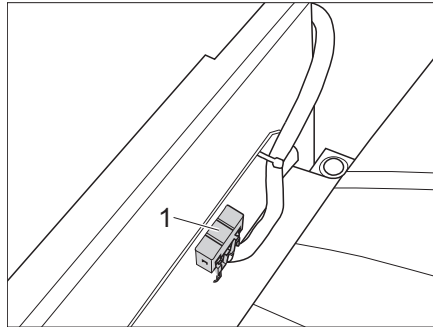

Fig. 56 Main fuse on the living area battery

Fuse for the cassette toilet

For information about replacing the fuse please refer to the separate instruction manual.

9.4.3 230 V combination automatic circuit breaker

The 230 V power supply system (external connection) is equipped with a combination automatic circuit breaker (Fig. 57,1) on the electrical box. This includes a residual-current-operated protective device (RCD) and line protection. The combination automatic circuit breaker is triggered by a short circuit, residual current or overload in the mains supply.

The residual-current-operated protective device is conducted via the supply line of the outdoor network. In accordance with the EU directive this should exist in every feeder grid. This residual-current-operated protective device should be checked at every new supply point for safety reasons.

If the automatic circuit breaker triggers during operation, the reason has to be determined and to be eliminated by disconnecting the appliance from the power supply system. In case of any doubt, please contact a qualified electrician or the Service of your brand dealer.

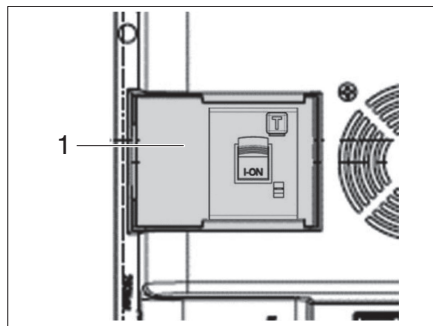

Fig. 57 230 V combination automatic circuit breaker

9.5 Control panel D100

Location The control panel D100 is located above the bench seat in the living area. It serves to control the electric power supply and provides an overview of the device states.

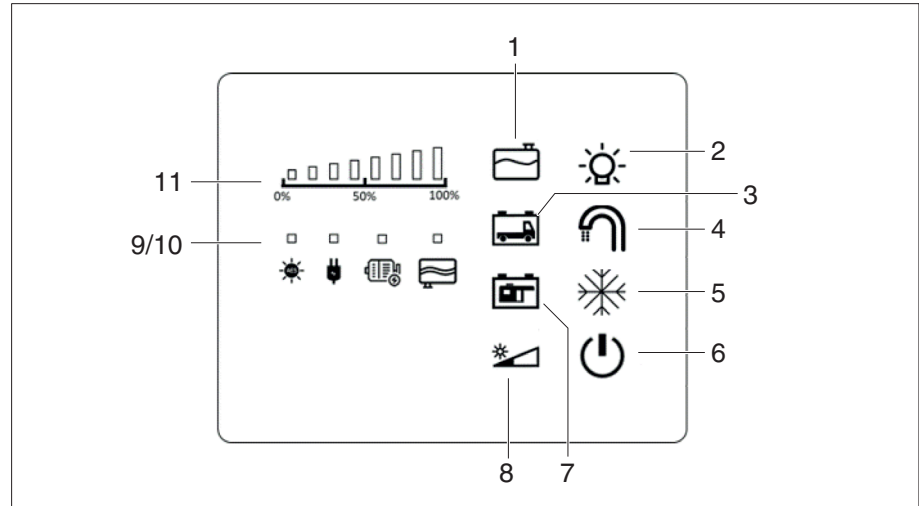





Fig. 58 Control panel D100

- 1 Control button for the fresh water fill level
(active = blue, inactive = white, refill mode = flashing blue)
- 2 Button for the power supply for load circuit A and B
(active = green (1x: A active, 2x: A and B active/inactive = white))
- 3 Control button for the starter battery
(active = blue, inactive = white, warning = flashing white)
- 4 Button for the water pump power supply
(active = green, inactive = white)
- 5 Button for the refrigerator power supply
(active = green, inactive = white)
- 6 Power button for switching the control panel on and off while simultaneously activating/deactivating load circuit C
- 7 Control button for the living area battery
(active = blue, inactive = white, warning = flashing red)
- 8 Dimming button
 - a) for dimming the control panel lighting, five brightness levels available
 - b) for activating night mode (active = red)
- 9 Signal LEDs for charging the living area battery
 - a) by solar panel (AES, green LED)
 - b) 230 V grid connection (yellow LED)
 - c) alternator (yellow LED)
- 10 Signal LEDs for the waste water tank warning (red LED)
- 11 LED control display
 - a) for the fresh water fill level in %
 - b) for the voltage of the starter and living area battery in %

9.5.1 Charging mode

The control panel uses signal LEDs (Fig. 58,9) to indicate which power source is being used to charge the living area battery.

Symbol	Power supply
	Solar panel
	230 V grid connection
	Alternator

If the solar panel is integrated and there is sufficient power, the AES signal LED is green. If the battery is charged by the 230 V grid supply or the alternator while the engine is running, the corresponding signal LED lights up yellow.



- ▷ To prevent the vehicle from driving off with the 230 V grid connection plugged in, a warning tone sounds as soon as the vehicle engine is started. The signal LED for the 230 V grid connection and the signal LED for the alternator will flash on the control panel.

9.5.2 Control panel lighting brightness

The power button (Fig. 58,6) is used to switch the control panel on and off. The lighting is set to medium brightness as standard and can be manually adjusted by pressing the dimming button (Fig. 58,8). Regardless of the configured brightness level, the lighting is dimmed when inactive and reactivated by pressing any button. The most recently set brightness level will be maintained. The dimming button (Fig. 58,8) is always yellow, except in night mode.

9.5.3 Night mode





In order to ensure unrestricted operation, the control panel must remain switched on. Night mode deactivates control panel lighting to avoid producing any disruptive light sources.

The control panel switches to night mode when the dimming button is pressed and held down (Fig. 58,8). Only the dimmer button is illuminated dimly in red to avoid confusion with a switched-off control panel.

Night mode can be cancelled by pressing any button, whereby the lighting will be reactivated at the lowest brightness level.

9.5.4 Warnings

Various safety mechanisms are available to protect the battery and equipment.

Note	LED/button	Deactivation
Fresh water tank	Control button (Fig. 58,1) flashing red	 Filling tank
Waste water tank	Signal LED (Fig. 58,10) red	 Emptying the tank
Starter battery	Control button (Fig. 58,3) flashing white	 Charging the starter battery
Living area battery	Control button (Fig. 58,7) flashing red	 Charging the living area battery

The warnings are automatically reset when the battery/equipment status changes.

Fresh water tank

If the fresh water level is very low, the control button (Fig. 58,1) flashes red. Filling the tank and reaching a threshold deactivates the warning message. Certain thresholds are indicated acoustically with refill mode.



- ▷ When the fresh water tank is almost empty, the water pump is automatically deactivated repeatedly after switch on to prevent the pump from running idle.

Waste water tank

The warning for the waste water tank is indicated by a signal LED (Fig. 58,10) flashing red. The signal LED lights up when the waste water tank has a residual capacity of less than 2 litres.



- ▷ The tank needs to be emptied as soon as possible to prevent it from overflowing.

Starter battery

If the starter battery voltage is very low, the corresponding control button (Fig. 58,3) on the control panel flashes white. If the vehicle is connected to solar or shore power, the electrical box ensures that the starter battery remains charged. In order to fully charge the battery, the vehicle needs to move to permit charging to take place via the alternator.



- ▷ The manufacturer's instructions and safety precautions must be observed in order to ensure the starter battery is charged in a safe, effective manner.

**Living area battery/
battery protection** If the living area battery voltage is very low, the corresponding control button (Fig. 58,7) on the control panel flashes red. If the living area battery is not charged, the battery voltage will sink again. Battery protection engages once the battery reaches a critical value.

Battery protection All switchable consumers are de-energised to prevent any further discharging of the battery. The power supply to the heater, step and load circuit D is not disconnected. A repeating sound signal is issued before switch off.
Once the living area battery has been charged, the consumers can be monitored again on the control panel or the power supply re-activated.

Fresh water refill mode The control panel provides acoustic feedback for the fill level when the fresh water tank is being refilled. This can be activated by pressing and holding the control button (Fig. 58,1) for the fresh water fill level.

The button flashes once successfully activated. Fill level management varies depending on the type of tank installed. Once the fill level reaches approx. 80% of the actual tank volume, an acoustic tone sounds. As the level of liquid rises, the sound intervals become shorter to prevent overflowing. The sounds stop once refill mode is deactivated. To deactivate refill mode, press the control button (Fig. 58,1) again.



- ▷ During refill mode, you cannot switch to another status view. Refill mode needs to be deactivated first.
- ▷ The detected and actual fill level may vary based on the type of tank used.

9.6 Control panel D110

The control panel D110 is located above the bench seat in the living area. It serves to control the electric power supply and provides an overview of the device states.

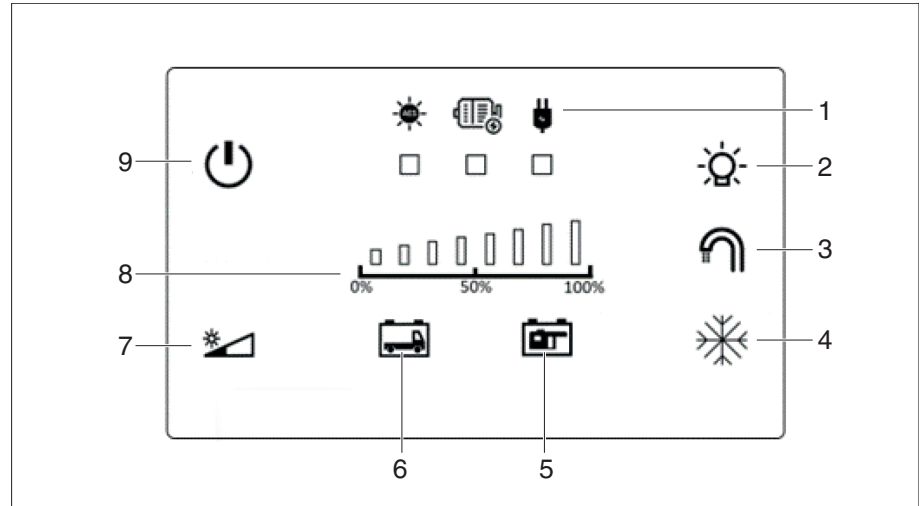





Fig. 59 Control panel D110

- 1 Signal LEDs for charging the living area battery
 - a) by solar panel (AES, green LED)
 - b) 230 V grid connection (yellow LED)
 - c) alternator (yellow LED)
- 2 Button for the power supply for load circuit A and B
(active = green (1x: A active, 2x: A and B active/inactive = white)
- 3 Button for the water pump power supply
(active = green, inactive = white)
- 4 Button for the refrigerator power supply
(active = green, inactive = white)
- 5 Control button for the living area battery
(active = blue, inactive = white, warning = flashing red)
- 6 Control button for the starter battery
(active = blue, inactive = white, warning = flashing white)
- 7 Dimming button
 - a) for dimming the control panel lighting, five brightness levels available
 - b) for activating night mode (active = red)
- 8 LED control display for the voltage of the starter and living area battery in %
- 9 Power button for switching the control panel on and off while simultaneously activating/deactivating load circuit C

9.6.1 Charging mode

The control panel uses signal LEDs (Fig. 59,1) to indicate which power source is being used to charge the living area battery.

Symbol	Power supply
	Solar panel
	230 V grid connection
	Alternator

If the solar panel is integrated and there is sufficient power, the AES signal LED is green. If the battery is charged by the 230 V grid supply or the alternator while the engine is running, the corresponding signal LED lights up yellow.



- ▷ To prevent the vehicle from driving off with the 230 V grid connection plugged in, a warning tone sounds as soon as the vehicle engine is started. The signal LED for the 230 V grid connection and the signal LED for the alternator will flash on the control panel.

9.6.2 Control panel lighting brightness

The power button (Fig. 59,9) is used to switch the control panel on and off. The lighting is set to medium brightness as standard and can be manually adjusted by pressing the dimming button (Fig. 59,7). Regardless of the configured brightness level, the lighting is dimmed when inactive and reactivated by pressing any button. The most recently set brightness level will be maintained. The dimming button (Fig. 59,7) is always yellow, except in night mode.

9.6.3 Night mode

In order to ensure unrestricted operation, the control panel must remain switched on. Night mode deactivates control panel lighting to avoid producing any disruptive light sources.



The control panel switches to night mode when the dimming button is pressed and held down (Fig. 59,7). Only the dimmer button is illuminated dimly in red to avoid confusion with a switched-off control panel.

Night mode can be cancelled by pressing any button, whereby the lighting will be reactivated at the lowest brightness level.

9.6.4 Warnings for the starter and living area battery

If the battery voltage is very low, the control buttons (Fig. 59,5) and (Fig. 59,6) will flash on the control panel.

- Press the control button (Fig. 59,5).
The charging status of the corresponding battery will be displayed on the LED control display (Fig. 59,8).

Note	LED/button	Deactivation
Starter battery	Control button (Fig. 59,6) flashing white	 Charging the starter battery
Living area battery	Control button (Fig. 59,5) flashing red	 Charging the living area battery

The warnings are automatically reset when the battery status changes.

Starter battery

If the starter battery voltage is very low, the corresponding control button (Fig. 59,6) on the control panel flashes white. If the vehicle is connected to solar or shore power, the electrical box ensures that the starter battery remains charged. In order to fully charge the battery, the vehicle needs to move to permit charging to take place via the alternator.



- ▷ The manufacturer's instructions and safety precautions must be observed in order to ensure the starter battery is charged in a safe, effective manner.

Living area battery/ battery protection

If the living area battery voltage is very low, the corresponding control button (Fig. 59,5) on the control panel flashes red. If the living area battery is not charged, the battery voltage will sink again. Battery protection engages once the battery reaches a critical value.

Battery protection

All switchable consumers are de-energised to prevent any further discharging of the battery. The power supply to the heater, step and load circuit D is not disconnected. A repeating sound signal is issued before switch off.

Once the living area battery has been charged, the consumers can be monitored again on the control panel or the power supply re-activated.

9.7 Control panel D200

The control panel D200 is located above the bench seat in the living area. It serves to control the electric power supply and provides an overview of the device states.

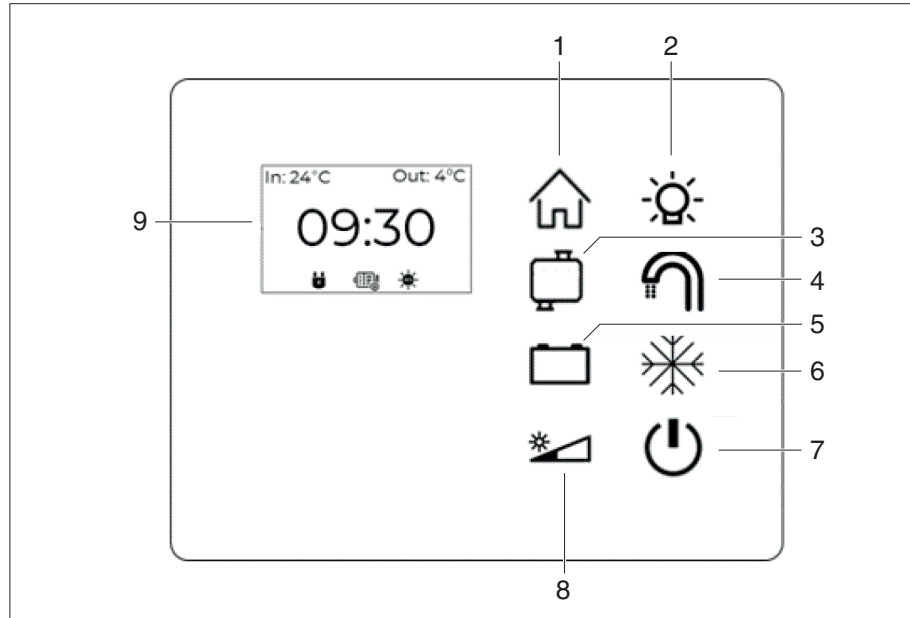

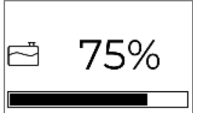

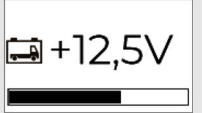
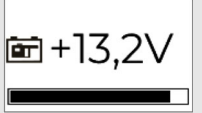

Fig. 60 Control panel D200

- 1 Home button (active = blue, inactive = white)
- 2 Button for the power supply for load circuit A and B
(active = green (1x: A active, 2x: A and B active/inactive = white))
- 3 Control button to display the fresh water and waste water fill level
(active = blue, inactive = white, refill mode = flashing blue)
- 4 Button for the water pump power supply
(active = green, inactive = white)
- 5 Control button to display the starter and living area battery
(active = blue, inactive = white, warning = flashing white/red)
- 6 Button for the refrigerator power supply
(active = green, inactive = white)
- 7 Power button for switching the control panel on and off while simultaneously activating/deactivating load circuit C
- 8 Dimming button
 - a) for dimming the control panel lighting, five brightness levels available
 - b) for activating night mode (active = red)
- 9 Control display to show
 - a) the time, temperature and charging mode
 - b) the fresh water and waste water fill level in %
 - c) the voltage of the starter and living area battery in %

Control display status views

The control display view switches to the corresponding display mode by pressing the buttons (Fig. 60,1, 3 and 5).

No. in Fig. 60	Display mode	Display
1	Home display for the following information: <ul style="list-style-type: none"> ● Inside and outside temperature ● Time ● Living area battery charging mode <ul style="list-style-type: none"> - 230 V grid connection - alternator or - solar panel (AES) 	
3	Level indicator in % <ul style="list-style-type: none"> ● for the fresh water tank ● for the waste water tank 	 
5	Battery charge status in % <ul style="list-style-type: none"> ● for the starter battery ● for the living area battery 	 

9.7.1 Setting the time in the control display

Time setting mode is activated by pressing and holding down on the home button (Fig. 60,1). Afterwards, only the time will be shown in the control display. A cursor will flash below the hour display (HH:MM).

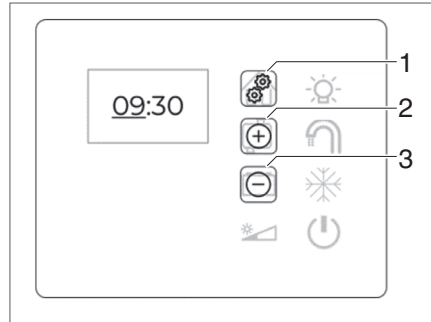





Fig. 61 Setting the time

- Press the home button (Fig. 61,1) down and hold it.
A cursor will flash under the hour display.
- Use the control buttons (Fig. 61,2) and (Fig. 61,3) to increase (+) or reduce (-) the hour display by one.
- Press the home button (Fig. 61,1).
The hour display is saved; the cursor will flash under the minute display.
- Use the control buttons (Fig. 61,2) and (Fig. 61,3) to increase (+) or reduce (-) the minute display by one.
- Press the home button (Fig. 61,1).
The time is saved. Time setting mode is exited and all symbols are shown in the control display.

9.7.2 Charging mode

When the home button (Fig. 60,1) is pressed, the control panel indicates which power source is being used to charge the living area battery in the control display.

Symbol	Power supply
	Solar panel
	230 V grid connection
	Alternator

If the battery is charged by the 230 V grid supply or the alternator while the engine is running, the corresponding signal is shown in the home display. If the solar panel is integrated and there is sufficient power, the AES symbol is displayed and the battery is charged in this way.



- ▷ To prevent the vehicle from driving off with the 230 V grid connection plugged in, a warning tone sounds as soon as the vehicle engine is started. The signal LED for the 230 V grid connection and the signal LED for the alternator will flash on the control panel.

9.7.3 Control panel lighting brightness

The power button (Fig. 60,7) is used to switch the control panel on and off. The lighting is set to medium brightness as standard and can be manually adjusted by pressing the dimming button (Fig. 60,8). Regardless of the configured brightness level, the lighting is dimmed when inactive and reactivated by pressing any button. The most recently set brightness level will be maintained. The dimming button (Fig. 60,8) is always yellow, except in night mode.

9.7.4 Night mode





In order to ensure unrestricted operation, the control panel must remain switched on. Night mode deactivates control panel lighting to avoid producing any disruptive light sources.

The control panel switches to night mode when the dimming button is pressed and held down (Fig. 60,8). Only the dimmer button is illuminated dimly in red to avoid confusion with a switched-off control panel.

Night mode can be cancelled by pressing any button, whereby the lighting will be reactivated at the lowest brightness level.

9.7.5 Warnings

Various safety mechanisms are available to protect the battery and equipment.

Note	LED/button	Deactivation
Fresh water tank	Control button (Fig. 60,3) flashes red; status bar flashes	 Filling tank
Waste water tank	Control button (Fig. 60,3) flashes red; exclamation mark above status bar	 Emptying the tank
Starter battery	Control button (Fig. 60,5) flashes red; status bar flashes	 Charging the starter battery
Living area battery	Control button (Fig. 60,5) flashes white; status bar flashes	 Charging the living area battery

The warnings are automatically reset when the battery/equipment status changes.

9.7.6 Fresh water and waste water tank

If the fresh water fill level is very low or the waste water tank is almost full, the control button (Fig. 60,3) on the control panel flashes red. Press the control button to display the fill level status.

- Press the control button (Fig. 60,3).
The fill level of the fresh water or waste water tank can be checked on the status display.
- Press the control button (Fig. 60,3) again.
The fill level of the other tank can be checked on the status display.

Fresh water tank

If the fresh water tank fill level is very low, in addition to the control button (Fig. 62,1), the status bar (Fig. 62,2) for the fresh water tank will flash in the control display.

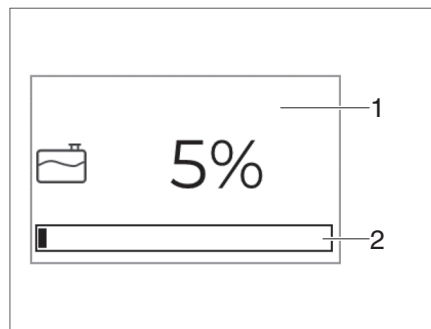

Fig. 62 Fresh water tank control button



- ▷ When the fresh water tank is almost empty, the water pump is automatically deactivated repeatedly after switch on to prevent the pump from running idle.

Fresh water refill mode

The control panel provides acoustic feedback for the fill level when the fresh water tank is being refilled. This can be activated by pressing and holding the control button (Fig. 60,3) for the fresh water fill level.

The button flashes once successfully activated. Fill level management varies depending on the type of tank installed. Once the fill level reaches approx. 80% of the actual tank volume, an acoustic tone sounds. As the level of liquid rises, the sound intervals become shorter to prevent overflowing. The sounds stop once refill mode is deactivated. To deactivate refill mode, press the control button (Fig. 60,3) again.



- ▷ During refill mode, you cannot switch to another status view. Refill mode needs to be deactivated first.
- ▷ The detected and actual fill level may vary based on the type of tank used.

Waste water tank

If the control button (Fig. 63,1) and the status display (Fig. 63,2) for the waste water tank are flashing in the control display and an exclamation mark “!” is displayed, the waste water tank only has a small remaining capacity.

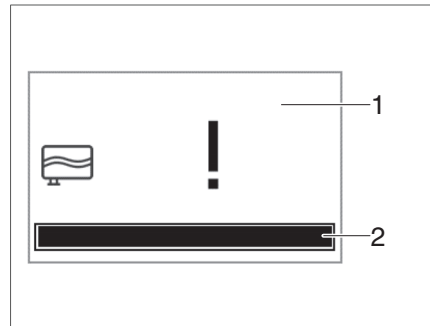

Fig. 63 Waste water tank control button



- ▷ The tank needs to be emptied as soon as possible to prevent it from overflowing.

9.7.7 Living area and starter battery

If the battery voltage is very low, the control button (Fig. 60,5) will flash red or white on the control panel.

- Press the control button (Fig. 60,5).
The charging status of the living area battery or the starter battery can be checked on the status display.
- Press the control button (Fig. 60,5) again.
The charging status of the other battery can be checked on the status display.

Living area battery/ battery protection

If the living area battery voltage is very low, the control button (Fig. 60,5) on the control panel flashes red. The status bar for the living area battery will also flash in the control display. If the living area battery is not charged, the battery voltage will sink again. Battery protection engages once the battery reaches a critical value.

Battery protection

All switchable consumers are de-energised to prevent any further discharging of the battery. The power supply to the heater, step and load circuit D is not disconnected. A repeating sound signal is issued before switch off.

Once the living area battery has been charged, the consumers can be monitored again on the control panel or the power supply re-activated.

Starter battery

If the starter battery voltage is very low, the corresponding control button (Fig. 58,5) on the control panel flashes white. The status bar for the starter battery will also flash in the control display. If the vehicle is connected to solar or shore power, the electrical box ensures that the starter battery remains charged. In order to fully charge the battery, the vehicle needs to move to permit charging to take place via the alternator.



- ▷ The manufacturer's instructions and safety precautions must be observed in order to ensure the starter battery is charged in a safe, effective manner.

9.8 Control panel D201

The control panel D201 is located above the bench seat in the living area. It serves to control the electric power supply and provides an overview of the device states.

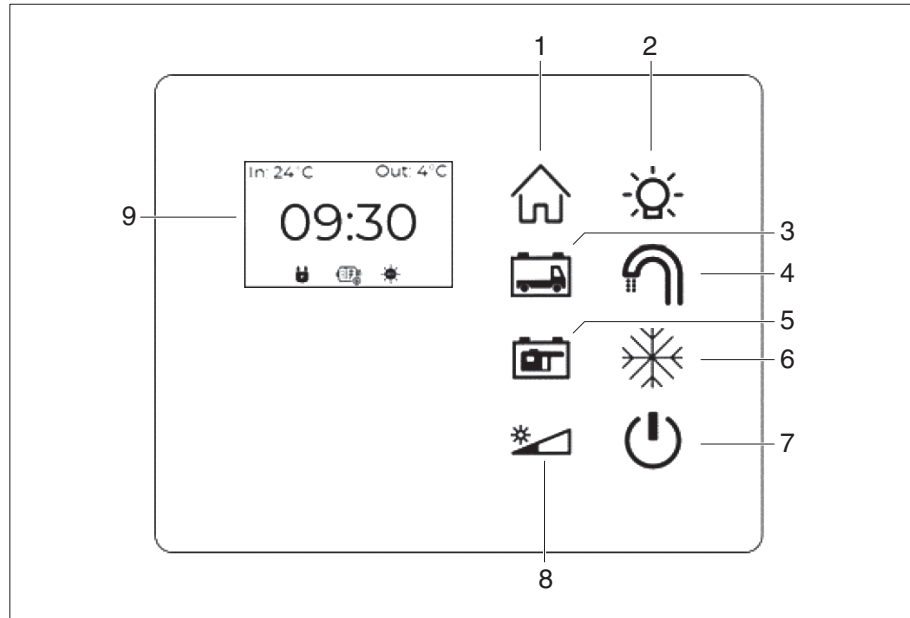

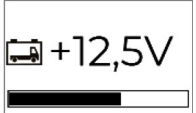
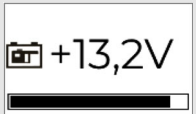

Fig. 64 Control panel D201

- 1 Home button (active = blue, inactive = white)
- 2 Button for the power supply for load circuit A and B
(active = green (1x: A active, 2x: A and B active/inactive = white)
- 3 Control button to display the starter battery
(active = blue, inactive = white, warning = flashing white)
- 4 Button for the water pump power supply
(active = green, inactive = white)
- 5 Control button to display the living area battery
(active = blue, inactive = white, warning = flashing white/red)
- 6 Button for the refrigerator power supply
(active = green, inactive = white)
- 7 Power button for switching the control panel on and off while simultaneously activating/deactivating load circuit C
- 8 Dimming button
 - a) for dimming the control panel lighting, five brightness levels available
 - b) for activating night mode (active = red)
- 9 Control display to show
 - a) the time, temperature and charging mode
 - b) the fresh water and waste water fill level in %
 - c) the voltage of the starter and living area battery in %

Control display status views

The control display view switches to the corresponding display mode by pressing the buttons (Fig. 64,1, 3 and 5).

No. in Fig. 64	Display mode	Display
1	Home display for the following information: <ul style="list-style-type: none"> ● Inside and outside temperature ● Time ● Living area battery charging mode <ul style="list-style-type: none"> - 230 V grid connection - alternator or - solar panel (AES) 	
3	Battery charging status of the starter battery in %	
5	Battery charging status of the living area battery in %	

9.8.1 Setting the time in the control display

Time setting mode is activated by pressing and holding down on the home button (Fig. 64,1). Afterwards, only the time will be shown in the control display. A cursor will flash below the hour display (HH:MM).





Fig. 65 Setting the time

- Press the home button (Fig. 65,1) down and hold it.
A cursor will flash under the hour display.
- Use the control buttons (Fig. 65,2) and (Fig. 65,3) to increase (+) or reduce (-) the hour display by one.
- Press the home button (Fig. 65,1).
The hour display is saved; the cursor will flash under the minute display.
- Use the control buttons (Fig. 65,2) and (Fig. 65,3) to increase (+) or reduce (-) the minute display by one.
- Press the home button (Fig. 65,1).
The time is saved. Time setting mode is exited and all symbols are shown in the control display.

9.8.2 Charging mode

When the home button (Fig. 64,1) is pressed, the control panel indicates which power source is being used to charge the living area battery in the control display.

Symbol	Power supply
	Solar panel
	230 V grid connection
	Alternator

If the battery is charged by the 230 V grid supply or the alternator while the engine is running, the corresponding signal is shown in the home display. If the solar panel is integrated and there is sufficient power, the AES symbol is displayed and the battery is charged in this way.



- ▷ To prevent the vehicle from driving off with the 230 V grid connection plugged in, a warning tone sounds as soon as the vehicle engine is started. The signal LED for the 230 V grid connection and the signal LED for the alternator will flash on the control panel.

9.8.3 Control panel lighting brightness

The power button (Fig. 64,7) is used to switch the control panel on and off. The lighting is set to medium brightness as standard and can be manually adjusted by pressing the dimming button (Fig. 64,8). Regardless of the configured brightness level, the lighting is dimmed when inactive and reactivated by pressing any button. The most recently set brightness level will be maintained. The dimming button (Fig. 64,8) is always yellow, except in night mode.

9.8.4 Night mode



In order to ensure unrestricted operation, the control panel must remain switched on. Night mode deactivates control panel lighting to avoid producing any disruptive light sources.

The control panel switches to night mode when the dimming button is pressed and held down (Fig. 64,8). Only the dimmer button is illuminated dimly in red to avoid confusion with a switched-off control panel.

Night mode can be cancelled by pressing any button, whereby the lighting will be reactivated at the lowest brightness level.

9.8.5 Warnings for the starter and living area battery

Various safety mechanisms are available to protect the batteries and equipment.

Note	LED/button	Deactivation
Starter battery	Control button (Fig. 64,3) flashes red; status bar flashes	 Charging the starter battery
Living area battery	Control button (Fig. 64,5) flashes white; status bar flashes	 Charging the living area battery

The warnings are automatically reset when the battery/equipment status changes.

Living area battery/ battery protection

If the living area battery voltage is very low, the control button (Fig. 64,5) on the control panel flashes red. The status bar for the living area battery will also flash in the control display. If the living area battery is not charged, the battery voltage will sink again. Battery protection engages once the battery reaches a critical value.

Battery protection

All switchable consumers are de-energised to prevent any further discharging of the battery. The power supply to the heater, step and load circuit D is not disconnected. A repeating sound signal is issued before switch off.

Once the living area battery has been charged, the consumers can be monitored again on the control panel or the power supply re-activated.

Starter battery

If the starter battery voltage is very low, the corresponding control button (Fig. 64,5) on the control panel flashes white. The status bar for the starter battery will also flash in the control display. If the vehicle is connected to solar or shore power, the electrical box ensures that the starter battery remains charged. In order to fully charge the battery, the vehicle needs to move to permit charging to take place via the alternator.



- ▷ The manufacturer's instructions and safety precautions must be observed in order to ensure the starter battery is charged in a safe, effective manner.

10.1 General



- ▷ The heat exchanger of the Truma hot-air heater has to be replaced after 30. Only the manufacturer of the heater or an authorised specialist workshop is allowed to replace the heat exchanger. The operator of the heater must see to it that the parts are replaced.
- ▷ For safety reasons, spare parts for pieces of heating appliances must correspond with manufacturer's instructions and be permitted by the manufacturer as a spare part. These spare parts may only be fitted by the manufacturer or an authorised specialist workshop.



- ▷ Further information can be obtained in the instruction manual for the respective appliance.

The appliances heater, boiler, cooker and refrigerator are fitted depending on the model of the vehicle.

In this instruction manual a description is given only for the operation of the appliances and their particular features.

To operate gas appliances, first open the regulator tap on the gas bottle and the gas isolator tap corresponding to the appliance.

10.2 Heater



- ▶ Never let gas escape unburned due to danger of explosion.
- ▶ Never run the heater in gas operation when filling the fuel tank, on ferries or in the garage. Danger of explosion!
- ▶ Never operate the heater in gas operation in closed rooms (e.g. garages). Danger of poisoning and suffocation!



- ▷ The circulation fan is automatically switched on when the hot-air heater is activated. During operation it is switched off and back on automatically by a thermostat control unit. This puts an immense strain on the living area battery, if the vehicle is not connected to an external 230 V power supply. Take into consideration that the living area battery only has limited reserves of energy.

Initial start-up

When lighting the heater for the first time a small amount of smoke and odour will occur. Immediately set the operating switch of the heater to its highest position. Open doors and windows and ventilate well. Smoke and odour will disappear by themselves after a while.

10.2.1 To heat properly

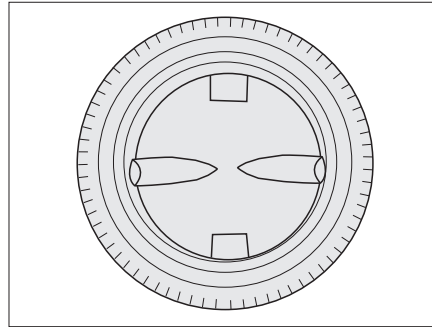

Fig. 66 Air outlet nozzle

Hot air distribution

Several air outlet nozzles (Fig. 66) are built into the vehicle. Pipes conduct the warm air to the air outlet nozzles. Turn the air outlet nozzles in a suitable position so the air can escape as required. To avoid draft close the air outlet nozzles on the dashboard and set the air distribution of the base vehicle to air circulation.

Adjusting the air outlet nozzles

- Fully open: full hot air flow
- Half or partially open: reduced hot air stream

When five air outlet nozzles are completely opened, less warm air escapes through each nozzle. However, if only three air outlet nozzles are opened, more warm air flows out of each nozzle.

10.2.2 Truma Combi hot-air heater



- ▶ Danger of poisoning through exhaust gases in closed rooms (e.g. garage, workshop)!

If the motorhome is parked in closed rooms:

- ▶ Shut off the fuel supply (gas or diesel) to the heater.
- ▶ Deactivate the timer of the control unit (OFF).
- ▶ Switch off the heater at the control unit.



- ▷ Do not use the space above and behind the heater as a storage compartment.



- ▷ Further information can be obtained in the separate manufacturer's instruction manual.

10.3 Boiler



- ▶ Never let gas escape unburned due to danger of explosion.
- ▶ When filling the fuel tank, on ferries or in the garage, never run the boiler in gas operation. Danger of explosion!
- ▶ Never operate the boiler in gas operation in closed rooms (e.g. garages). Danger of poisoning and suffocation!
- ▶ The water in the boiler can be heated up to 60 °C. Risk of scalding!



- ▷ Never use boiler when empty.
- ▷ If the boiler is not being used, empty it if there is any risk of frost.
- ▷ Only operate the boiler with the maximum temperature setting if you require a large quantity of warm water. This protects the boiler against the build-up of limescale.



- ▷ Do not use the water from the boiler as drinking water.

10.3.1 Safety/drainage valve

The boiler is equipped with a safety/drainage valve (Fig. 67). The safety/drainage valve prevents water in the boiler from freezing, when there is frost and the heater is not switched on. The safety/drain valve is installed near the heater or in the floor storage compartments under the table.



- ▷ When the vehicle is not used for a long period of time, open the safety/drainage valve and drain the boiler.
- ▷ At temperatures below approx. 3 °C the safety/drainage valve opens automatically. Before filling the boiler switch on the heater and wait until the temperature of the safety/drainage valve exceeds 7 °C. Only then can the safety/drainage valve be closed again.
- ▷ The water pump and the water fittings are not protected against freezing by the safety/drainage valve.



- ▷ The drainage neck of the safety/drainage valve has to be free of dirt (e.g. leaves, ice) at all times.

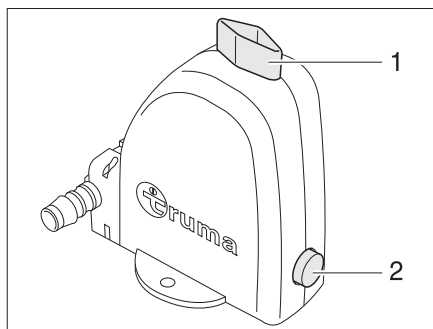

Fig. 67 Safety/drainage valve of the boiler

10.3.2 Filling/emptying the boiler

The boiler can be supplied with water from the water tank.

Filling the boiler with water:

- Switch on 12 V power supply on the panel.
- Close the safety/drainage valve. To do so turn the knob (Fig. 67,1) cross-wise to the safety/drainage valve and press in the push button (Fig. 67,2).
- Set all the water taps to "Hot" and open them. The water pump is turned on. The hot water pipes are filled with water.
- Keep the taps open until the water flowing out of the taps has no bubbles in it. This is the only way to ensure that the boiler is full of water.
- Close all water taps.

Emptying the boiler:

- Switch off the hot water boiler on the Truma operating panel.
 - Open the safety/drainage valve. To do so turn the knob (Fig. 67,1) parallel to the safety/drainage valve. The push button (Fig. 67,2) trips. The boiler is drained to the outside by the safety/drainage valve.
 - Check whether the water has been drained completely from the boiler (approx. 10 litres).
- ▷ Further information can be obtained from the separate instruction manual "Boiler".



10.4 Gas cooker



- ▶ Never let gas escape unburned due to danger of explosion.
- ▶ Before using the cooker make sure that there is sufficient ventilation. Open windows or the skylight.
- ▶ Do not use the gas cooker for heating purposes.
- ▶ Always protect your hands with cooking gloves or potholders when handling hot pots, pans and similar items. There is a risk of injury!
- ▶ During activation and operation of the gas cooker, no flammable or easily combustible objects such as dishcloths, napkins etc. may be near the gas cooker. Fire hazard!
- ▶ The process of ignition must be visible from above and must not be covered by cooking pans placed on the cooker.
- ▶ Depending on the model, the gas cooker lid is held closed by a spring. When closing there is danger of getting injured!



- ▷ Do not use the glass gas cooker lid as a hob.
- ▷ Do not close the gas cooker lid while the gas cooker is in operation.
- ▷ Do not apply pressure on the gas cooker lid when it is closed.
- ▷ Do not place hot cooking pans on the gas cooker lid.
- ▷ Keep the gas cooker lid open after cooking as long as the burner emits heat. The glass plate could otherwise burst.



- ▷ Use only pots and pans whose diameter is suitable for the burner grates of the gas cooker.
- ▷ When the flame fades, the thermocouple automatically cuts the gas supply.
- ▷ Further information can be obtained from the separate instruction manual "Gas cooker".

The vehicle kitchen unit is fitted with a two-burner gas cooker.

Switching on:

- Open the regulator tap on the gas bottle and the gas isolator tap "Cooker".
- Open the gas cooker lid.
- Turn the control knob on the burner you wish to use to the ignition position (large flame).
- Press down the control knob and hold it down.
- Ignite the burner with a gas lighter, a match or with other suitable means of lighting.
- When the flame burns, hold the control knob down for 10 to 15 seconds, until the thermocouple keeps the gas supply automatically open.
- Release the control knob and turn to the desired setting.
- If ignition was not successful, repeat the entire procedure.

Switching off:

- Turn the control knob to the 0-position. The flame fades.
- Close the gas isolator tap "Cooker" and the regulator tap on the gas bottle.

10.5 Refrigerator



- ▷ Further information can be obtained from the separate instruction manual.

11.1 Water supply, general



- ▶ Fill the water tank with fresh water only.
- ▶ Water left standing in the water tank or in the water pipes becomes undrinkable after a short period. For this reason, rinse the water pipes and the water tank thoroughly with several litres of fresh water before each use of the vehicle. To do this, open all water taps. After each use of the vehicle completely empty the water tank and the water pipes.



- ▷ If the vehicle is not used for several days or if it is not heated when there is a risk of frost, empty the entire water system. Leave the water taps on in central position. Leave the safety/drainage valve (if available) and all drain cocks open. Frost damage to appliances, frost damage to the vehicle and deposits in water-carrying components can be avoided in this way.
- ▷ The water pump will overheat without water and can get damaged. Never operate water pump when the water tank is empty.

The vehicle is equipped with a fitted water tank.

An electric water pump pumps the water to the individual water taps. Opening a water tap automatically switches on the water pump and pumps water to the tap.

The waste water tank collects the waste water. The water level in the water and waste water tanks can be checked on the panel.



- ▷ Before using the water fittings, the 12 V power supply on the panel must be switched on. Otherwise the water pump will not work.
- ▷ The water supply system conforms to the latest state of technology 03/2009 (Directive 2002/72/EC).

11.2 Emptying the water system

If the water system is not used for a longer period, particular in winter, the complete water system has to be emptied.

Emptying:

- Open all the water taps to the central position and leave them in this position. If necessary, blow out with compressed air.
- Open the drain valve of the boiler and the fresh water tank and leave them in this position.

11.2.1 Emptying the fresh water tank



- ▷ Replace the fresh water tank if possible every 3 - 4 days, because bacteria can develop after a few days.
- ▷ Ensure that the lid of the water filler neck is always closed when the vehicle is unsupervised.

Drainage opening

The drainage opening for the fresh water tank is located at the lowest point of the tank.

Fresh water tank The fresh water tank is located in the left-hand or right-hand rear area under the bed.

Opening the fresh water tank:

- Remove the mattress.
- Open the flap to the tank area.

Emptying the fresh water tank:

- Ensure that the water pump is switched off.
- Turn the knob for draining the tank (Fig. 68,1) counter-clockwise until slight resistance can be felt.
The fresh water is drained down to 20 litres
- Turn the knob (Fig. 68,1) further counter-clockwise.
The tank is drained completely.
- To close the drain turn the knob clockwise until it stops (Fig. 68,1).
If the tank contents amounts to less than 30%, it is drained completely immediately when the knob is opened.

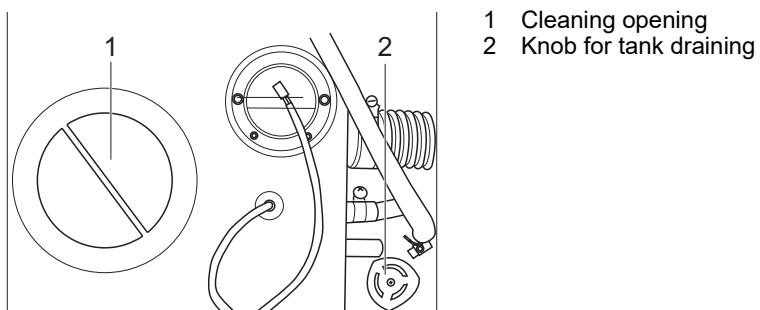

Fig. 68 Fresh water tank

Opening cleaning openings:

- Screw out and remove the cleaning openings (Fig. 69).
The drain opening can be accessed now.
- Clean the tank with common cleaning agents.
- After completing cleaning, close both openings.

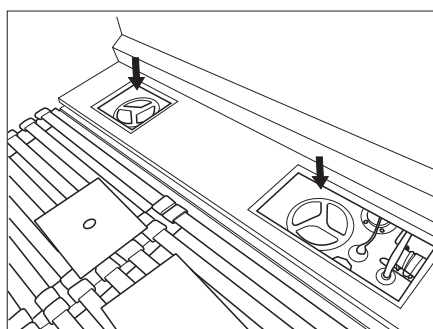

Fig. 69 Cleaning openings fresh water tank (illustration similar)

11.2.2 Emptying the waste water tank



- ▷ Never pour sewage into the waste water tank.
- ▷ Clean the tank regularly since solids can accumulate in the waste water tank through the sink drains.

Volume

The water tank holds 100 l.

The waste water tank is located under the vehicle floor.

The drain nozzle is located on the right-hand vehicle side to the front of the rear wheel.

The level of the waste water tank is indicated on the control panel. If the tank is filled about 80%, the control symbol on the control panel flashes and an acoustic signal sounds.

Emptying the waste water tank:

- Put the tank key (Fig. 71) on the drain device (Fig. 70,1).
- In order to open the waste water tap, turn the tank key (Fig. 71) a quarter turn anticlockwise (Fig. 72).
- Completely empty waste water tank.
- To close the waste water tap, turn the tank key (Fig. 71) back clockwise as far as it will go.

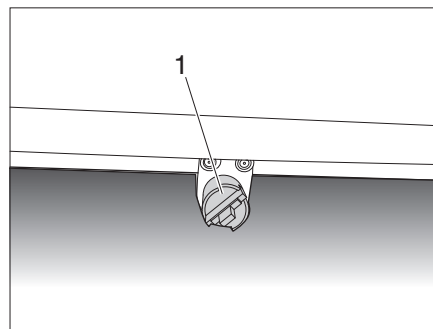

Fig. 70 Drain waste water tank

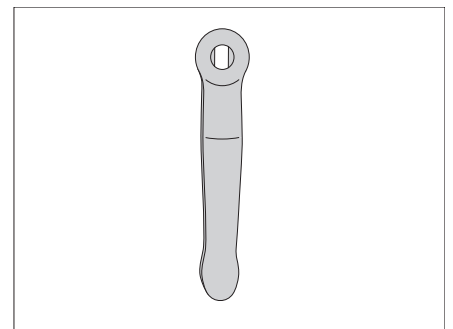

Fig. 71 Tank key

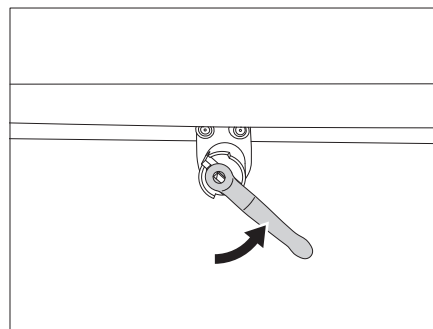

Fig. 72 Open water tap

11.2.3 Waste water tank with electric ball valve (optional)

The switch for the electric drain valve is located in the service flap of the cassette toilet. Refer to the instructions manual of the respective manufacturer.

11.2.4 Filling the fresh water tank



- ▶ When filling the water tank, observe the maximum permissible gross weight of the vehicle.



- ▷ Do not fill the fresh water tank until it flows over.
- ▷ Make sure that both of the service openings in the water tank are firmly closed and sealed. Check and service the service opening seals on a regular basis.
- ▷ The water pump will overheat without water and can get damaged. Never operate water pump when the water tank is empty.
- ▷ If the vehicle is not used for several days or if it is not heated when there is a risk of frost, empty the entire water system. Leave the water taps on in central position. Leave the safety/drainage valve (if available) and all drain cocks open. Frost damage to appliances, frost damage to the vehicle and deposits in water-carrying components can be avoided in this way.



- ▷ The water level can be checked on the control panel while the water tank is being filled.

Fresh water filler neck

The filler neck for filling the fresh water tank is located on the passenger side in the rear area or respectively on the driver's side in the rear area.

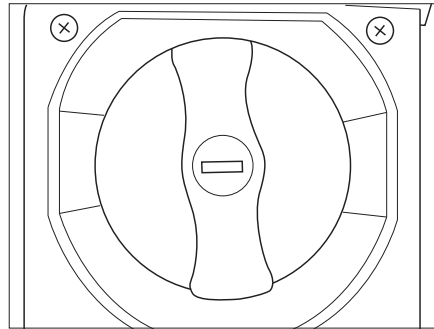

Fig. 73 Fresh water tank filler opening

Filling the fresh water tank:

- Position the vehicle horizontally.
- Ensure that the drainage opening in the inside of the fresh water tank (Fig. 68), the waste water tap (Fig. 70,1) and the safety valve of the hot water boiler are closed.
- Open the cover flap. Open the cap with the body key and turn it counter-clockwise half a turn under slight pressure.
- Remove the key. A brief click indicates that the locking mechanism of the lid is opened. Screw off the cap half a turn counter-clockwise (bayonet lock).
- Fill the fresh water tank via the filler opening by means of a suitable filling hose or canister (Fig. 73).
The fresh water tank is provided with an overflow. If the tank is full, the excess water flows through it to the outside below the vehicle.
- When the fresh water tank is filled 100%, screw the cap back on, lock it and close the cover flap.

11.3 Starting up the water supply

Starting up the water supply:

- Switch on the control panel with main button.
- Switch on the water pump at the control panel. The indicator light indicates the operation.
- When the water tap is opened in the "warm" position (red point at the water tap), the boiler and the lines are filled with water from the fresh water tank. Ensure that the vehicle interior temperature exceeds +5 °C so that the frost monitor of the boiler is not triggered.
- The filling process of the boiler takes a few minutes.
- When the water flows without air bubbles the boiler is filled. The resultant lack of water in the fresh water tank can be topped up.

11.4 Water system



- ▷ The water system is not a pressurized-water system.

The water system and the tapping points in the kitchen, bathroom, shower and toilet must be checked for leaks regularly and in particular at the beginning of the season.

The water pump is put into operation via microswitches when the various water taps (kitchen and bath) are opened or when the toilet is flushed. The pump is self-priming. For the operation of the water system the control panel has to be switched on and the water supply has to be activated.

11.4.1 Winter package (special equipment)



- ▷ In the case of low temperatures there is a risk that all the water-bearing lines as well as the hot water boiler can freeze up.
- ▷ Since the heater mat has a considerable power consumption, the external power system (230 Volt) has to be connected.

With the winter package which is available as special equipment the vehicle is suitable for winter use up to outdoor temperatures of a max. of -10 °C and at the same time an indoor temperature of at least +18 °C to +20 °C.

The waste water tank is equipped with a heater mat that prevents freezing of the waste water tank when it is switched on.

If there is a risk of frost, switch the switch of the tank heater at the control panel to the position "On".

The heater mat is controlled by means of a thermostat and switches off again at a temperature of +5 °C.

11.5 Cassette toilet



- ▷ Further information can be obtained from the separate instruction manual.

11.5.1 Commissioning the cassette toilet



- ▷ Never add sanitary fluid through the sliding cover or through the toilet bowl.
- ▷ Do not use any force when pushing the sewage tank in. This can result in serious damage.

Commissioning:

- Pull the securing clip upwards.
- Pull the sewage tank outwards until it stops and tilt it slightly. Take out the tank completely.
- Place the tank level with the outlet neck upwards.
- Turn the cap with dosing cup at the inside of the outlet neck and pour the specified amount of sanitary fluid into the sewage tank. Add two litres of water so that the bottom of the sewage tank is filled completely.
- Turn the dosing cup back onto the outlet neck. Turn the outlet neck back into the original position.
- Slide the sewage tank through the door into its original position.
- Ensure that the sewage tank is locked with the securing clip. Lock the service door.

11.5.2 Operation of the cassette toilet



- ▷ Do not leave any water in the bowl when the toilet is not being used.
- ▷ The sewage in the toilet may never be emptied into the public waste water and rain water system since the sanitary fluid contains chemicals.
- ▷ Do not press the aeration knob until the outlet neck points downwards.
- ▷ Depending on the model, the swivel range of the toilet may be impaired. Take care to ensure that it does not come into contact with the wall or other components.

Operation:

- Swivel the toilet bowl into the desired position.
- Press the flush button or open the sliding cover to let a bit of water run into the bowl.
- After the cassette toilet has been used, open the sliding cover (if it is still closed) and press the flush button to flush the toilet.
- After flushing close the sliding trap.

Emptying:

- The sewage tank has to be emptied at the latest when the LED indicator lights up. It is advisable to already empty the sewage tank beforehand. The LED indicator lights up when the sewage tank contains more than 15 litres. From this moment on a residual capacity of 2 litres remains (± 5 usages).
- Ensure that the sliding cover is closed. Open the service door on the outside of the vehicle. Pull the securing clip upwards and remove the sewage tank.
- Use the handles to carry the tank to a normal toilet or to an other permitted disposal station. Place the tank vertically on the floor and turn the outlet neck upwards.

- Remove the lid of the outlet neck. Grasp the sewage tank at the upper handle that is located next to the outlet neck. Grasp the rear handle with the other hand in such a manner that the aeration knob can be pressed with the thumb during emptying. Keep the aeration knob pressed while the tank is emptied.
- Flush the tank thoroughly with water after emptying. Also clean the sliding cover with water. Slide the sewage tank into the toilet and close the service door.

Storage:

- Discharge the central water system.
 - Press the flush button until the remaining water has been pumped away.
 - Empty the sewage tank.
 - Let the sewage tank dry before it is closed with the lid.
- ▷ Do not use household products (chlorine, solvents or other strong cleaning agents). These can cause permanent damage to the seals and other parts of the toilet.
- ▷ The sealing ring of the sliding cover is a part of the toilet that is subject to wear. Depending on the extent and the type of maintenance the functionality of the sealing ring is reduced after some time and has to be replaced.

**Cleaning and maintenance:**

- Regularly clean the seals of the sewage tank, automatic ventilation and lid.
- Clean the seals and sliding covers with bath cleaner.
- If the toilet has not been used for a longer period, clean the seals and treat with care products. Do not use Vaseline or plant-based oils.
- Let the sewage tank dry before it is closed with the lid.

11.5.3 Using the toilet in winter

- ▷ The use of antifreeze agents is not advisable for environmental reasons.

The cassette toilet can be used normally at cold temperatures if the toilet is in a warm environment. If this is not the case, the toilet can freeze. In this case the water has to be drained from the toilet.

11.6 Bathroom unit / toilet usage



- ▶ Ensure for driving that the swing wall is fastened and secured (latches in audibly) in the right-hand position (Fig. 74) at the magnetic holder. While travelling ensure that the door of the bathroom unit is open and is secured by means of the supplied bracket.
- ▶ While travelling or when not in use ensure that the shower head is located in the corresponding fixture.



- ▷ When the vehicle is not used for a longer period of time, close the roller blind of the wet cell. This prevents the roller blind from warping due to thermal fluctuations.

The bathroom is divided into two sections. Fig. 74 shows the toilet with washbasin, Fig. 75 shows the shower in the bathroom.



Fig. 74 Toilet with washbasin (illustration similar)

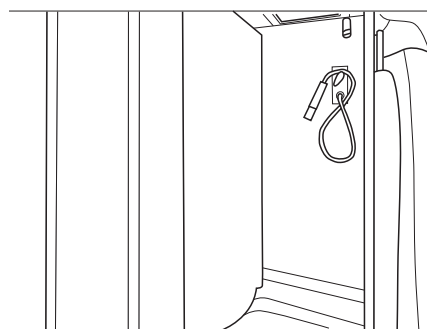

Fig. 75 Shower (illustration similar)

Using the bathroom sections:

- Move the swing wall to the desired position (left-hand/right-hand) to use the individual bathroom sections.
- The swing wall is secured in the left-hand and right-hand end position by means of a magnetic holder. When using ensure that the wall latches audibly into the end position.

The following positions are provided:

- Swing wall right-hand end position for using the toilet and the washbasin, see Fig. 74
- Swing wall left-hand end position for using the shower, see Fig. 75

12.1 External care

12.1.1 Washing with a high-pressure cleaner



- ▷ Do not clean the tyres with a high-pressure cleaner. The tyres might be damaged.
- ▷ Do not spray external applications (deco-films) directly with the high-pressure cleaner. The external applications could come off.

Before cleaning the vehicle with a high-pressure cleaner, observe the operating instructions of the high-pressure cleaner.

When cleaning with the nozzle for circular jet between the vehicle and the cleaning nozzle, maintain a minimum distance of approx. 700 mm.

Take into consideration that the jet of water comes out of the cleaning nozzle with pressure. The vehicle may be damaged by incorrect handling of the high-pressure cleaner. The temperature of the water should not be above 60 °C. Keep the jet of water in constant movement during the washing process. Do not direct the water jet at clearances, built-in electrical parts, plugs, seals, ventilation grills or skylights. The vehicle may be damaged or water may enter the interior.

12.1.2 Washing the vehicle



- ▷ Never have the vehicle cleaned in a car wash. Water can penetrate in the refrigerator grills, the waste gas vents, the ventilations of the extractor hoods or in the forced ventilations. The vehicle could be damaged.
- ▷ Whenever the paintwork of the motorhome is soiled for example with sea salt, road salt, insects, tar, bird droppings and other aggressive substances, clean the paintwork immediately.
- ▷ The motorhome should be cleaned regularly with water near the seaside and in winter (road salt).
- ▷ Stepping on the roof of the motorhome is not permitted.
- Wash the vehicle only on a washing site intended for this purpose. Avoid full sunshine. Observe environmental measures.
- Only clean external applications and synthetic parts with plenty of warm water, dish washing liquid and soft cloth.
- Wash down the vehicle with plenty of water, a clean sponge or a soft brush. In the case of stubborn dirt add dish washing liquid to the water.
- Add-on parts made of glass-fibre reinforced plastic (GRP) require a regular follow-up treatment with a polisher. This way these parts will not turn yellow and the sealing of the surface remains intact.
- Treat rubber seals of doors and storage flaps with talc.
- Treat locking cylinder of doors and storage flaps with graphite dust.

12.1.3 Windows of acrylic glass

Acrylic glass windows are delicate and require very careful handling.



- ▷ Never rub acrylic glass windows when dry as dust particles might damage the surface.
- ▷ Only clean acrylic glass windows with plenty of warm water, dish washing liquid and a soft cloth.
- ▷ Never use glass cleaning agents with chemical, abrasive or alcohol-containing additives. Premature brittleness of the panes and associated cracks may result from their use.
- ▷ Avoid contact of cleansing agents used for the body (e.g. tar- or silicone-removing agents) with acrylic glass.
- ▷ Do not drive into car wash units.
- ▷ Do not apply stickers to the acrylic glass windows.
- ▷ After cleaning the vehicle rinse the acrylic glass windows again with sufficient clear water.
- ▷ Treat rubber seals with glycerine.



- ▷ Acrylic glass cleanser with antistatic effect is suitable for a follow-up treatment. Small scratches can be treated with acrylic glass polish. These agents are available at the accessories shop.

12.1.4 Waste water tank

Clean the waste water tank after every use of the vehicle as motorhome, at least several times a year.

- Cleaning:*
- Empty the waste water tank.
 - Thoroughly rinse out the waste water tank with fresh water.
 - If possible, clean waste water sensors through the cleaning opening by hand.

12.1.5 Fresh water tank

Empty and clean the fresh water tank after every use of the vehicle.

Common cleaning agents for water tanks can be used to clean the fresh water tank. Agents such as diluted citric acid or vinegar water can also be used.

- Cleaning:*
- After completing cleaning close both service openings and close the cover.



- ▷ Check and service the service opening seals on a regular basis.

12.1.6 Entrance step

If the entrance step is lubricated, coarse particles of dirt can settle on the lubricant during the journey and cause damage to the operating mechanism of the entrance step. Therefore, do not lubricate the moving parts of the entrance step.

12.1.7 Cleaning and care of the external synthetic parts

The following substances may not come into contact with synthetic surfaces:

- Stain remover
- Benzene
- Acetone
- Nail polish remover
- Iodine tincture

12.1.8 Relieving the Skyroofs[®] rubber seal



- ▷ In order to ensure the long service life and optimal seal performance of the Skyroof[®], the rubber seal is regularly relieved over an extended period of time.

The seal should be relieved when the vehicle is parked for extended periods, i.e. during winter.

Relieving the rubber seal:

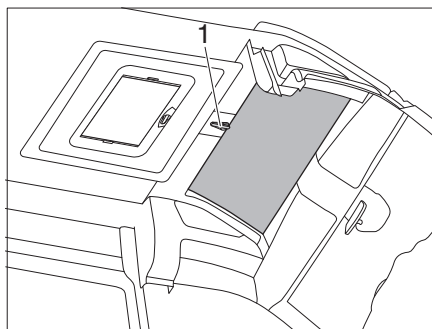

Fig. 76 SkyRoof[®]

- Open the latch and turn the crank a half rotation (Fig. 76,1).

The seal then expands and the Skyroof is optimally sealed again when closed.

12.2 Interior care



- ▷ If possible, treat stains immediately.
- ▷ Acrylic glass windows are delicate and require very careful handling (see Chapter 9.1.3).
- ▷ Synthetic parts in the toilet and living area are very delicate and should be treated with care. Do not use solvents, alcohol-containing cleaning agents or scourers containing sand. This procedure will help you to avoid brittleness and formation of cracks.
- ▷ Do not pour any corrosive agents into the drain holes. Never pour boiling water directly into the drain holes. Corrosive agents and boiling water cause damage to drainage pipes and siphon traps.
- ▷ Do not use vinegar based products to clean the toilet and water system, or for decalcification of the water system. Vinegar-based products may cause damage to seals or parts of the installation. Use standard decalcifying products for decalcification.
- ▷ Save water. Mop up all remaining water.



- ▷ The service centres of our dealers will be glad to provide information about the use of maintenance products.
- Surface and knobs of furniture, lamps and synthetic parts in the toilet and living area should be cleaned with water and a wool cloth. A mild cleanser may be added to the water. If necessary, treat finished surfaces with furniture polish.
- Clean upholstery with dry foam specially manufactured for the use on upholstery or with the foam of a mild detergent. Do not wash upholstery. Protect upholstery from direct sunlight so that it does not lose its colour.
- Curtains and net curtains should be dry cleaned.
- Clean PVC-floor covering with a mild, soapy cleanser for PVC floors. Do not place carpet on wet PVC-floor covering. The carpet and the PVC-floor covering may stick together.
- Never clean the sink or the gas cooker with a scourer. Avoid anything which may cause scratching or grooves.
- Clean gas cooker only with a moist cloth. Prevent any water from penetrating the gas cooker. Water may damage the gas cooker.
- Brush insect screens on windows and skylights with a soft brush or vacuum with the brush attachment of the vacuum cleaner.
- Brush blinds with a soft brush or vacuum with the brush attachment of the vacuum cleaner. Grease or stubborn dirt may be removed with a mild soap at 30 °C (curd soap).
- Brush Roman shades with a soft brush or vacuum with the brush attachment of the vacuum cleaner. Grease or stubborn dirt may be removed with a mild soap at 30 °C (curd soap).
- Unrolled seat belts can be cleaned with warm soapsuds. The seat belts must be completely dry before being rolled up.
- Clean water tank with water and dish washing liquid and rinse subsequently with plenty of fresh water.

12.3 Winter care



- ▷ If there is any risk of frost, always run heater at a minimum of 15 °C. Set the circulation fan (if existing) to automatic mode. In the case of extreme external temperatures, the furniture flaps and doors should be left slightly open. The inflowing warm air can help prevent the freezing of water pipes, for example, and counteract the formation of condensation in the storage spaces.
- ▷ If there is any risk of frost, cover the outside surface of the windows with winter insulation mats empty the waste water tank.
- ▷ Always keep forced-air ventilation systems open, possibly also open the skylight slightly.
- ▷ If there is any risk of frost, water fittings in an unheated motorhome have to remain open, also when the water supply is emptied. In particular ensure that the mixing faucet is opened in the middle position and remains in this position.

12.3.1 Winter operation

During winter operation, condensation develops when the vehicle is occupied under low-temperature conditions. To ensure good interior air quality and avoid vehicle damage from condensation, sufficient ventilation is essential.

- When heating the vehicle, the heater should be at the highest setting and roof storage cabinets, curtains and blinds should be opened. This ensures optimal ventilation.
- In the morning, lift up all cushions, air out storage boxes and dry any damp areas.



- ▷ If condensation has still developed, just wipe it off.



12.4 Lay-up

12.4.1 Temporary lay-up



- ▶ After the vehicle has been standing for a longer period (approx. 10 months) have the braking and gas systems checked by an authorised specialist workshop.
- ▶ Take into consideration that water is undrinkable after only a short time.

Before laying up the vehicle, go through the following checklist:

	Activities	done
Base vehicle	Completely fill fuel tank. This can prevent corrosion to the tank system	
	Jack up the vehicle so that the wheels do not bear any load, or move the vehicle every 4 weeks. This prevents any pressure points from occurring on tyres and wheel bearings	
	Protect the tyres from direct exposure to the sun. Danger of formation of cracks!	
	Inflate tyres up to the recommended maximum pressure	
	Always provide for sufficient ventilation in the underbody area	
	 ▶ Humidity or lack of oxygen e.g. by covering with plastic film may cause optical irregularities to the underbody. Also observe the specifications in the operating instructions of the base vehicle	
Interior	Place upholstery in an upright position for ventilation, and cover	
	Clean refrigerator	
	Allow refrigerator and freezer compartment doors to remain slightly open	
Gas system	Close regulator tap on the gas bottle	
	Close all gas isolator taps	
	Always remove gas bottles from the gas bottle compartment, even if they are empty	
Electrical system	Fully charge living area and starter battery	
	 ▶ Charge the battery for at least 20 hours before laying up. Disconnect the living area battery from the 12 V power supply	
Water system	Empty the entire water system. Blow out the residual water from the water pipes (0.5 bar max.). Leave the water taps on in central position. Leave the safety/drainage valve (if available) and all drain cocks open. Observe the notes in Chapter 8	
	Check all the water tapping points as well as kitchen, bath, shower, and toilet for leakage.	



- ▶ When returning the motorhome to service check whether the filled water system leaks. This is also advisable before starting every journey and should be repeated at regular intervals.
- ▶ Damage that is caused by improper handling or by frost in the water system is not covered by the warranty or guarantee.

12.4.2 Winter lay-up

Additional measures are required if laying up the vehicle over winter:

	Activities	done
Base vehicle	Clean body and underbody thoroughly and spray with hot wax or protect with varnish	
	Fill fuel tank with winter diesel	
	Check the frost protection in the cooling water	
	Repaint paint damage	
Body	Keep the forced ventilation open	
	Clean and grease all door and flap hinges	
	Brush oil or glycerine on all locking mechanisms	
	Rub all rubber seals with talc	
	Use graphite dust to treat locking cylinders	
Interior	Position de-humidifiers	
	Remove upholstery from the vehicle and store in a dry place	
	Air the interior every 3 weeks	
	Empty all cabinets and storage compartments, open flaps, doors and drawers	
	Thoroughly clean the interior	
Electrical system	Remove the starter battery and living area battery and store in a place protected from frost (see Chapter 9)	
Water system	Clean the water system using a cleaning agent from a specialised store	
	Check all the water tapping points as well as kitchen, bath, shower, and toilet for leakage.	
Complete vehicle	Arrange the tarpaulins in such a way that the ventilation openings are not covered, or use porous tarpaulins	

12.4.3 Starting up the vehicle after a temporary lay-up or after lay-up over winter

Go through the following checklist before start-up:

	Activities	done
Base vehicle	Check the tyre pressure on all tyres	
	Check the tyre pressure of the spare wheel	
Body	Clean dust and dirt from the entrance step	
	Check that the doors, windows and skylights are working properly	
	Check the function of all external locks	
	Remove the cover from the waste gas vent of the heater (if there is one)	
	Remove the winter cover from the refrigerator grills (if there is one)	
Gas system	Put the gas bottles in the gas bottle compartment, tie down and connect to the gas pressure regulator	
Electrical system	Connect to 230 V external power supply	
	Fully charge living area and starter battery	
	 ▷ Charge at least for 20 hours after laying up.	
	Connect the living area battery with the 12 V power supply (see Chapter 9)	
	Check that the electrical system are working, e.g. interior light, socket and all installed electrical appliances	
Water system	Use several litres of fresh water to rinse out water pipes and water tank. To this end, open all water taps	
	Check the functionality of the operating lever for the waste water tank	
	Close safety/drainage valve, drain cocks and water taps	
	Check all the water tapping points as well as kitchen, bath, shower, and toilet for leakage.	
Appliances	Check the function of the refrigerator	
	Check the function of the heater/boiler	
	Check the function of the gas cooker	

13.1 Official inspections

An official general inspection (HU) of roadworthiness has to be carried out by a recognised body (such as "TÜV", "DEKRA") at regular intervals in accordance with Section 29 of the German Traffic Licencing Regulations ("Straßenverkehrsulassungsordnung" (StVZO)) on vehicles that are registered in Germany.

The respective local regulations apply in other counties.

An authorised specialist workshop has to inspect the gas system every 2 years. This also applies for not registered vehicles. Modifications to the gas system must be checked immediately by an authorised specialist workshop. The authorised specialists workshop certifies the inspection and the proper state in a gas inspection certificate. The gas inspection sticker is applied on the rear of the vehicle near the licence plate.

13.2 Inspection work

Like any technical appliance, the vehicle must be inspected at regular intervals.

This inspection work must be carried out by qualified personnel.

The service centre in charge will confirm the work performed.

Have chassis inspections confirmed in the chassis manufacturer's customer service booklet.



- ▷ Observe the inspections specified by the manufacturer and have them carried out at the specified intervals. The value of the vehicle is thus preserved.
- ▷ The confirmation of the inspection work carried out also serves as valid proof in the case of damage and claims under the guarantee.

13.3 Maintenance work

As with every machine, this vehicle requires maintenance. The extent and frequency of the maintenance work required depend on conditions of operation and use. More difficult operating conditions make it necessary to service the vehicle more often.

Have the basic vehicle and the appliances serviced at the intervals specified in the corresponding instruction manuals.

13.4 Replacing lamps



- ▶ Bulbs and light fittings can be extremely hot. Therefore, allow lights to cool down before changing bulbs.
- ▶ Before changing bulbs, switch off the power supply at the safety cut-out in the 230 V fuse box.
- ▶ Store bulbs in a safe place inaccessible to children.
- ▶ Do not use any bulb that has been dropped or which shows scratches in its glass. The bulb might burst.
- ▶ Lights can get very hot. When the light is switched on, a safety distance of 30 cm to combustible material has to be maintained. Fire hazard!



- ▷ New bulbs should not be touched with the fingers. Use a cloth when inserting the new bulb.
- ▷ Only use bulbs of the same type and with the correct wattage.

13.5 Spare parts



- ▶ Every alteration of the original condition of the vehicle can alter road behaviour and jeopardize road safety.
- ▶ The special equipment and original spare parts recommended by us have been specially developed and supplied for your vehicle. Your dealer has these products. Your dealer is informed about admissible technical details and carries out the required work correctly.
- ▶ The use of accessories, parts and fittings not approved by us may cause damage to the vehicle and jeopardise road safety. Even if an expert's report, a general type approval or a design certification exists, there is no guarantee for the proper quality of the product.
- ▶ No liability can be assumed for damage caused by products which have not been approved by us. This also applies to impermissible alterations to the vehicle.

For safety reasons, spare parts for pieces of equipment must correspond with manufacturer's instructions and be permitted by the manufacturer as a spare part. These spare parts may only be fitted by the manufacturer or an authorised specialist workshop. The authorised dealers are available for any spare parts requirement.

When ordering spare parts, please indicate the serial number and the vehicle type to your authorised dealer.

The vehicle described in this instruction manual is built and equipped to factory standards. Special equipment is offered depending on its purpose or use. When fitting special equipment check if such equipment has to be entered in the vehicle documents. Observe the max. permissible gross weight. Your authorised dealer will be pleased to advise you.

13.6 Vehicle identification plate

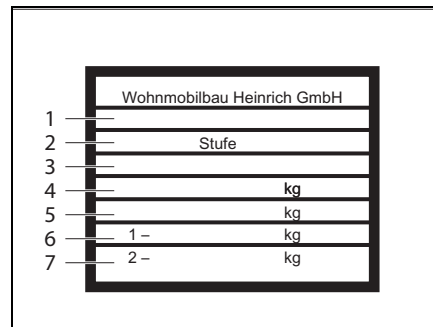

- 1 EC type approval number
- 2 Manufacturer of the unit (add-on unit)
- 3 Chassis number
- 4 Maximum permissible gross weight of the vehicle
- 5 Maximum permissible gross weight of the vehicle with trailer
- 6 Permissible axle load front
- 7 Permissible axle load rear

Vehicle identification plate (similar to type plate)

The vehicle identification plate with the serial number is located on the B-column of the driver's side above the deadbolt.

Do not remove the vehicle identification plate. The vehicle identification plate:

- Identifies the vehicle
- Helps with the procurement of spare parts
- Together with the vehicle documents identifies the vehicle owner

13.7 Warning and information stickers

There are warning and information stickers on and inside the vehicle. Warning and information stickers are for the sake of safety and must not be removed.



- ▷ Replacement stickers can be obtained from an authorised dealer or the service centre.

14.1 Electrical system



- ▷ When the living area battery is changed, only use batteries of the same type.



- ▷ See Chapter 9 for changing the fuses

Fault	Cause	Remedy
Interior lighting does not work	Bulb is defective	Unscrew cover of the relevant light, replace bulb. Note volts and watts specifications
	Fuse on the electrical box is defective	Replace fuse on the electrical box
The electrically operated entrance step cannot be moved in or out	Fuse on the electrical box is defective	Replace fuse on the electrical box
No 230 V power supply despite connection	230 V automatic circuit breaker has triggered	Switch on 230 V automatic circuit breaker
Starter or living area battery is not charged when operated in 230 V mode	40 A strip fuse on the starter battery or on the living area battery faulty	Changing the 40 A strip fuse on the starter battery or on the living area battery
	Charger is defective	Contact customer service
Living area battery is not charged during vehicle operation	Fuse on terminal D+ of the alternator is defective	Replace fuse
	Disconnecter relay in the charger is defective	Contact customer service
12 V indicator lamp does not light up	12 V power supply switched off	Switch 12 V power supply on
	Starter or living area battery is not charged	Charge the starter or living area battery
	Cutoff relay on the electrical box is defective	Contact customer service
	Main fuse in the living area battery is defective	Replace main fuse in the living area battery

Fault	Cause	Remedy
12 V power supply does not work in 230 V operation	12 V power supply switched off	Switch 12 V power supply on
	Charger is defective	Contact customer service
	230 V automatic circuit breaker has triggered	Contact customer service
	Main fuse on the living area battery faulty	Change main fuse on the living area battery
Starter battery is discharged in 12 V operation	Disconnecter relay on the charger is defective	Contact customer service
No voltage is supplied by the living area battery	Living area battery is discharged	Charge living area battery immediately  ▷ Total discharge damages the battery. If the vehicle is to be laid up for a long period, fully charge the living area battery beforehand

14.2 Gas system



- ▶ In case of a defect of the gas system (gas odour, high gas consumption) there is danger of explosion! Close the regulator tap on the gas bottle immediately. Open doors and windows and ventilate well.
- ▶ In case of a defect in the gas system: Do not smoke; do not ignite any open flames, and do not operate electric switches (light switches etc.).
- ▶ Have the defect in the gas system repaired by an authorised specialist workshop.

Fault	Cause	Remedy
No gas	Gas bottle empty	Changing gas bottles
	Gas isolator tap closed	Open the gas isolator tap
	Regulator tap on the gas bottle is closed	Open regulator tap on the gas bottle
	Outdoor temperature too low (-42 °C for propane gas, 0 °C for butane gas)	Wait for higher external temperatures
	Built-in appliance is defective	Contact customer service

14.3 Cooker

Fault	Cause	Remedy
Ignition fuse does not operate (flame does not burn after the control knobs are released)	Heat-up time is too short	Keep control knob pressed for approx. 15 to 20 seconds after ignition
	Ignition fuse is defective	Contact customer service
Flame extinguishes when being reduced to its minimum setting	Thermocouple sensor is incorrectly set	Set thermocouple sensor correctly (do not bend). The sensor tip should protrude by 5 mm beyond the burner. The sensor neck should not be more than 3 mm away from the burner ring; if necessary, contact customer service

14.4 Heater/Boiler

In the event of a defect contact the nearest customer service workshop of the relevant appliance manufacturer. The list of addresses is enclosed with the accompanying appliance documentation. Only authorised qualified personnel may repair the appliance.

Fault	Cause	Remedy
Heater does not ignite	Temperature sensor at the control unit or remote sensor defective	Remove the connector at the control unit. The heater then functions without the thermostat. Contact the customer service as soon as possible
Red indicator lamp "Fault" illuminates	Air in the gas pipe system	Switch off and on again. After two futile ignition attempts, wait for 10 minutes before trying again.
	Lack of gas	Open regulator tap and gas isolator tap
		Connect a full gas bottle
	Defect of a safety element	Contact customer service
Red indicator lamp "Fault" flashes	Operating voltage too low	Charge, have charged or renew the living area battery

Fault	Cause	Remedy
Green indicator lamp behind knob is not lit	Fuse on the power supply unit is defective	Replace the fuse on the power supply unit
	Fuse in the electronic control unit has been triggered	Contact customer service
	Living area battery defective	Charge, have charged or renew the living area battery
Boiler empties, safety/drainage valve has opened	Temperature at the drainage valve below approx. 3 °C	Switch on the heater. At temperatures below approx. 3 °C the drainage valve opens automatically.
Safety/drainage valve does not close during switching on	Temperature at the drainage valve below approx. 7 °C	Switch on the heater. When heater is not operating, drainage valve only closes again at temperatures above approx. 7 °C.

14.5 Refrigerator

In the event of a defect contact the nearest customer service workshop of the relevant appliance manufacturer. The list of addresses is enclosed with the accompanying appliance documentation. Only authorised qualified personnel may repair the appliance.

Fault	Cause	Remedy
Refrigerator does not cool when operating in 230 V mode	On-board fuse is defective	Insert a new fuse
	Vehicle not connected to the power supply	Establish a power supply connection
Refrigerator does not cool when operating in 12 V mode	On-board fuse is defective	Insert a new fuse
	Battery discharged	Check battery and charge
	Ignition not switched on	Start engine

14.6 Water supply

Fault	Cause	Remedy
Leakage water inside the vehicle	A leak has occurred	Identify leak, re-connect water pipes
No water	Water tank is empty	Top up with fresh water
	Drain cock not closed	Close drain cock
	12 V power supply switched off	Switch 12 V power supply on
	Fuse of the water pump is defective	Replace fuse on the electrical box
	Water pump defective	Exchange water pump (have it exchanged)
	Water pipe snapped off	Straighten water pipe or replace
	Electrical box is defective	Contact customer service
Toilet has no flush water	Water tank is empty	Top up with fresh water
	Fuse for cassette is defective	Replace fuse
Display for water and waste water indicates a wrong value	Measuring probe in the waste water or water tank is soiled	Clean water/waste water tank
	Measuring probe is defective	Replace measuring probe
Waste water tank cannot be emptied	Drain cock is clogged	Open the cleaning cap on the waste water tank and drain the waste water. Rinse the waste water tank well
Water drains from washbasin or shower slowly or not at all	Waste water tank full	Empty the waste water tank. If the waste water tank is filled to about 50%, the water drains slower. Do not use chemicals for cleaning if the drain lines are blocked. Eliminate the clogging with hot water, a suction unit or compressed air.

14.7 Body

Fault	Cause	Remedy
Hinges/joints in the bathroom unit/toilet compartment are difficult to operate/make a grating noise	Hinges/joints are not sufficiently lubricated	Lubricate hinges/joints with solvent-free and acid-free grease  ▷ Spray cans often contain solvents
Storage compartment hinges are difficult to operate/make a grating noise	Storage compartment hinges are not sufficiently lubricated	Lubricate storage compartment hinges with acid-free and resin-free grease



- ▷ The authorised dealers and service centres are available for any spare parts requirement.

